

RWYB116_Lite

2.4GHz Ultra Low Power Wi-Fi / Bluetooth 5.0 Classic BR EDR 2.1
UART Interface DIP Module with Integrated Antenna

Datasheet

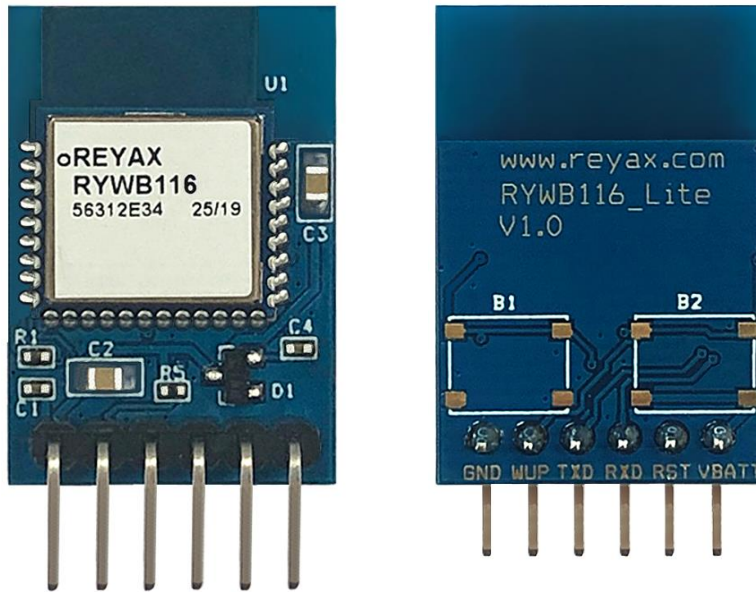

PRODUCT DESCRIPTION

REYAX's RYWB116_Lite DIP module provides a comprehensive multi-protocol wireless solution including 802.11 b/g/n, dual-mode Bluetooth 5.

FEATURES

- Compliant to single-spatial stream IEEE 802.11 b/g/n, Bluetooth 5.
- Co-existence of multiple wireless protocols managed by an internal protocol arbitration manager.
- Ultra-low power consumption with multiple power modes to reduce the system energy consumption.
- Leading edge RF performance providing long range and higher throughputs.
- Support for 20 / 40 MHz channel bandwidths.
- Transmit power up to +21dBm with integrated PA.
- Wi-Fi receive sensitivity as low as -98.5 dBm.
- BT receive sensitivity as low as -95 dBm.
- Support for Client mode, Access point mode, Wi-Fi Direct and enterprise security.
- Support for concurrent Wi-Fi, Bluetooth 5.
- 8.9 mA transmit current in BT 5 mode, 2 Mbps data rate
- Operating temperature: -40°C to +85°C

PIN DESCRIPTION

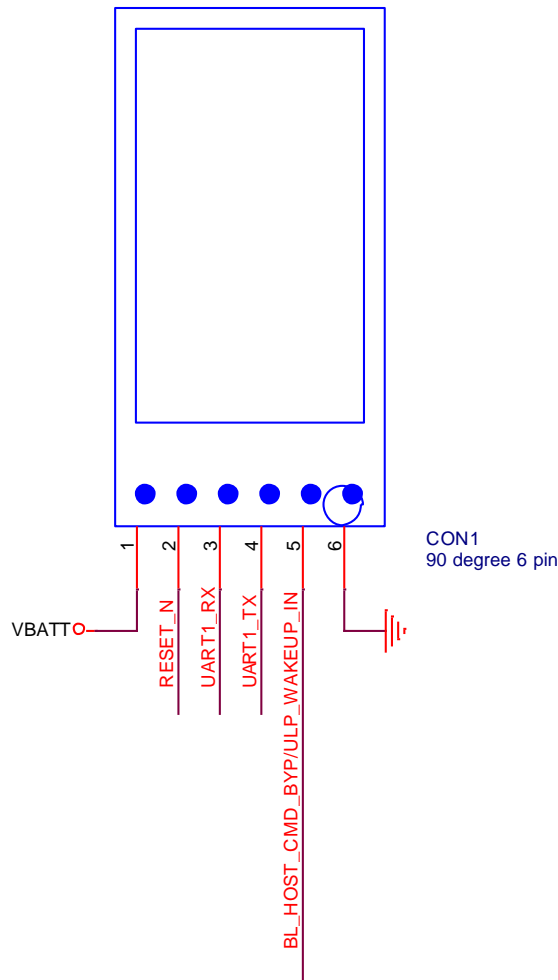

Pin	Name	I/O	Condition
1	VBATT	I	Input supply voltage (2.1-3.6V).
2	RESET_N	I	Active-low reset asynchronous reset signal.
3	UART1_RX	I	UART 1 interface serial input.
4	UART1_TX	O	UART 1 interface serial output.
5	BL_HOST_CMD_BYP/ ULP_WAKEUP_IN	I	This signal has two functionalities – one during the bootloading process and one after the bootloading. During bootloading, this signal is an active-high input to indicate that the bootloader should bypass any inputs from the Host processor and continue to load the default firmware from Flash. After bootloading, this signal is an active-high input to indicate that the chip/module should wakeup from its Ultra Low Power (ULP) sleep mode.
6	GND	-	Ground

INTERNAL SCHEMATIC

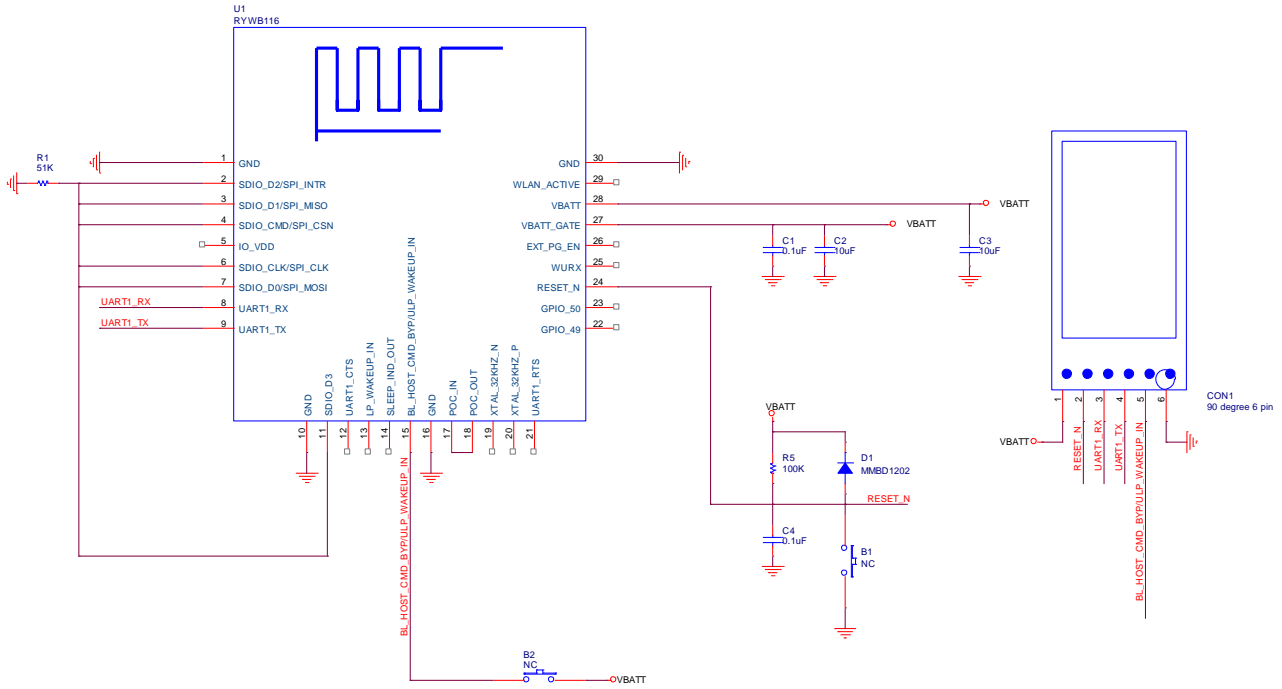

Title		RYWB116_Lite	
Size	Document Number	Rev	
CustomDoc>		1.0	
Date:	Monday, May 13, 2019	Sheet	1 of 1

SPECIFICATION

Item	Min.	Typical	Max.	Unit	Description
Operation Voltage	2.1	3.3	3.6	V	VBATT
TX Mode Current			400	mA	
WLAN Data Transfer Average Current		270		mA	11Mbps Tx
WLAN Data Receive Average Current		48.2		mA	72 Mbps Rx
WLAN Standby Associated Mode Current		119		uA	DTIM=3 Cisco Aironet AP
WLAN Standby Associated Mode Current		51		uA	DTIM=10 Cisco Aironet AP
Quiescent current		3		nA	
Baud Rate	9600	115200	921600	bps	
Wireless Protocols					IEEE 802.11b, 802.11g, 802.11n Bluetooth 5 (2.1+EDR, LE, LE 2 Mbp)
Operational Modes Supported					Wi-Fi Access Point with support for up to 8 clients Wi-Fi Client Wi-Fi Direct Bluetooth Classic (EDR v 2.1) Wi-Fi Client + Bluetooth Low Energy
Receive Power			10	dBm	
WLAN Modulation					OFDM with BPSK, QPSK, 16-QAM, and 64-QAM 802.11b with CCK and DSSS
WLAN Operating Frequency	2.412		2.484	GHz	
WLAN Bandwidth		20/40		MHz	
WLAN Data Rates	1 6		11 54	Mbps	802.11b: 1, 2, 5.5, 11Mbps 802.11g: 6, 9, 12, 18, 24, 36, 48, 54Mbps 802.11n: MCS0 to MCS7
Bluetooth Channel Spacing	1		2	MHz	BR, EDR, LE 1 Mbps, LR- 1 MHz LE 2 Mbps - 2 MHz
Bluetooth Modulation		GFSK, DQPSK, 8DPSK			
Bluetooth Operating Frequency	2.402		2.480	GHz	
Bluetooth Data Rates	125		3000	Kbps	
Weight		2.3		g	
Operating Temperature	-40	25	+85	°C	

DC CHARACTERISTICS

RESET_N PIN

Symbol	Min.	Typical	Max.	Unit	Parameter
V _{IH}	0.8 VDD		3.63	V	High level input voltage
V _{IL}	-0.5		0.3 VDD	V	Low-level input voltage
V _{hys}	0.05 VDD			V	Hysteresis voltage

DIGITAL INPUT OUTPUT SIGNALS

Symbol	Min.	Typical	Max.	Unit	Parameter
V _{IH}	2.0		3.63	V	High level input voltage
V _{IL}	-0.3		0.8	V	Low-level input voltage
V _{hys}	0.1 VDD			V	Hysteresis voltage
V _{OL}			0.4	V	Low level output voltage
V _{OH}	VDD-0.4			V	High level output voltage
I _{OL}	2.0	4.0	12.0	mA	Low level output current
I _{OH}	2.0	4.0	12.0	mA	High level output current

PIN CAPACITANCE

Symbol	Parameter	Min.	Typical	Max.	Unit
C _{io}	Input/output capacitance, digital pins only			2.0	pF

WIRELESS PERFORMANCE SPECIFICATIONS

WLAN 2.4 GHz TRANSMITTER CHARACTERISTICS

Parameter	Conditions	Min.	Typical	Max.	Unit
Transmit Power for 20MHz Bandwidth, compliant with IEEE mask and EVM	1 Mbps DSSS		20		dBm
	2 Mbps DSSS		20		dBm
	5.5 Mbps CCK		20		dBm
	11 Mbps CCK		20		dBm
	6 Mbps OFDM		21		dBm
	9 Mbps OFDM		21		dBm
	12 Mbps OFDM		21		dBm
	18 Mbps OFDM		20		dBm

	24 Mbps OFDM		19		dBm
	36 Mbps OFDM		18		dBm
	48 Mbps OFDM		18		dBm
	54 Mbps OFDM		17		dBm
	MCS0 Mixed Mode		20		dBm
	MCS1 Mixed Mode		20		dBm
	MCS2 Mixed Mode		20		dBm
	MCS3 Mixed Mode		19		dBm
	MCS4 Mixed Mode		17.5		dBm
	MCS5 Mixed Mode		17.5		dBm
	MCS6 Mixed Mode		17		dBm
	MCS7 Mixed Mode		14		dBm
Transmit Power for 40MHz Bandwidth, compliant with IEEE mask and EVM	MCS0 Mixed Mode		14		dBm
	MCS7 Mixed Mode		12		dBm

WLAN 2.4 GHz RECEIVER CHARACTERISTICS

Parameter	Conditions	Min.	Typical	Max.	Unit
Sensitivity for 20MHz Bandwidth	1 Mbps DSSS		-98.5		dBm
	2 Mbps DSSS		-93		dBm
	5.5 Mbps CCK		-90		dBm
	11 Mbps CCK		-88		dBm
	6 Mbps OFDM		-93		dBm
	9 Mbps OFDM		-92		dBm
	12 Mbps OFDM		-91		dBm
	18 Mbps OFDM		-89		dBm
	24 Mbps OFDM		-85.5		dBm
	36 Mbps OFDM		-82.5		dBm
	48 Mbps OFDM		-78		dBm
	54 Mbps OFDM		-76.5		dBm
	MCS0 Mixed Mode		-91.5		dBm
	MCS1 Mixed Mode		-90		dBm
	MCS2 Mixed Mode		-88		dBm
	MCS3 Mixed Mode		-85		dBm
	MCS4 Mixed Mode		-81		dBm
MCS5 Mixed Mode		-77		dBm	

	MCS6 Mixed Mode		-75		dBm
	MCS7 Mixed Mode		-73		dBm
Maximum Input Level for PER below 10%	1 Mbps DSSS		0		dBm
	11 Mbps CCK		-10		dBm
	54 Mbps OFDM		-10		dBm
	MCS0 Mixed Mode		-10		dBm
Adjacent Channel Rejection	1 Mbps DSSS		36		dB
	11 Mbps CCK		37		dB
	6 Mbps OFDM		38		dB
	54 Mbps OFDM		22		dB
Return Loss		-10			dB
RSSI Accuracy		-3		+3	dB

BLUETOOTH TRANSMITTER CHARACTERISTICS

Parameter	Conditions	Min.	Typical	Max.	Unit
Transmit Power	BR, EDR		14		dBm
	LE		20		dBm
Power Control Step	BR, EDR		3		dB
Adjacent Channel Power $ M-N = 2$	BR		-20		dB
	EDR		-20		dB
	LE		-20		dB
Adjacent Channel Power $ M-N > 2$	BR		-40		dB
	EDR		-40		dB
	LE		-30		dB

BLUETOOTH RECEIVER CHARACTERISTICS

Parameter	Conditions	Min.	Typical	Max.	Unit
Sensitivity	BR (1 Mbps), 339 bytes, DH5 Packet		-93.5		dBm
	EDR2 (2 Mbps), 679 bytes, 2-DH5 Packet		-94		dBm
	EDR3 (3 Mbps), 1020 bytes, 3-DH5 Packet		-88		dBm
	LE (1 Mbps), 37 bytes, Advertising Channel		-95		dBm
Maximum Input Level	BR, EDR2, EDR3		-16		dBm
	LE		-8		dBm
BER Floor				1e-4	%
C/I Performance	BR, co-channel		9		dB
	BR, adjacent +1 MHz		-2		dB
	BR, adjacent -1 MHz		-2		dB
	BR, adjacent +2 MHz		-19		dB
	BR, adjacent $\geq \pm 3 $ MHz		-19		dB
	BR, adjacent to image channel		-22		dB
	EDR2, co-channel		11		dB
	EDR2, adjacent +1 MHz		-2		dB
	EDR2, adjacent -1 MHz		-2		dB
	EDR2, adjacent +2 MHz		-17		dB
	EDR2, adjacent -2 MHz		-17		dB
	EDR2, adjacent $\geq \pm 3 $ MHz		-17		dB
	EDR3, co-channel		19		dB
	EDR3, adjacent +1 MHz		3		dB
	EDR3, adjacent -1 MHz		3		dB
	EDR3, adjacent +2 MHz		-12		dB
	EDR3, adjacent -2 MHz		-12		dB
	EDR3, adjacent $\geq \pm 3 $ MHz		-12		dB
	LE, co-channel		19		dB
	LE, adjacent +1 MHz		13		dB
LE, adjacent -1 MHz		13		dB	

	LE, adjacent +2 MHz		-19		dB
	LE, adjacent -2 MHz		-19		dB
	LE, adjacent $\geq \pm 3 $ MHz		-19		dB

DIMENSIONS

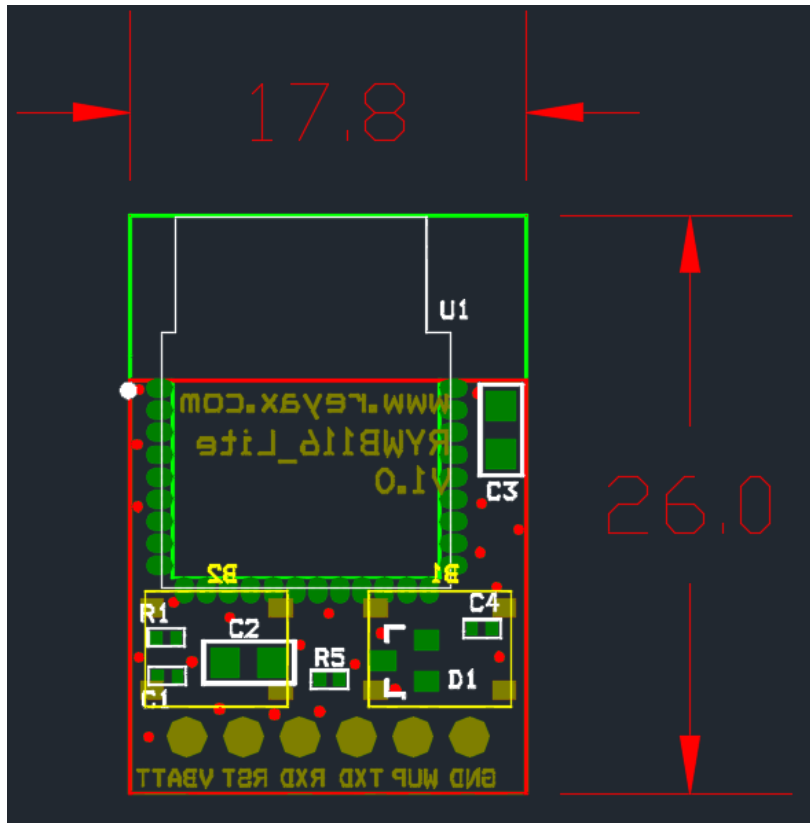

Unit : mm