

RYS8833

Ultra Low Power 1.8V UART/I2C interface GNSS module

Datasheet

11mm*8mm*2.2mm



PRODUCT DESCRIPTION

The RYS8833 **1.8V** GNSS module is a multi-GNSS module with high sensitivity, The RYS8833 also has integrated digital noise filters and spectrum analyzer.

FEATURES

- SONY CXD5605AGF Engine.
- A multi-GNSS module for GPS(L1 C/A), GLONASS(L1 OF), SBAS(L1 C/A), QZSS(L1 C/A), Galileo(E1 CBOC), and BeiDou(B1, specific Firmware).
- Including SAW filter, LNA and TCXO.
- Embedded digital noise filters and spectrum analyzer.
- UART / I2C Interface optional.

BLOCK DIAGRAM

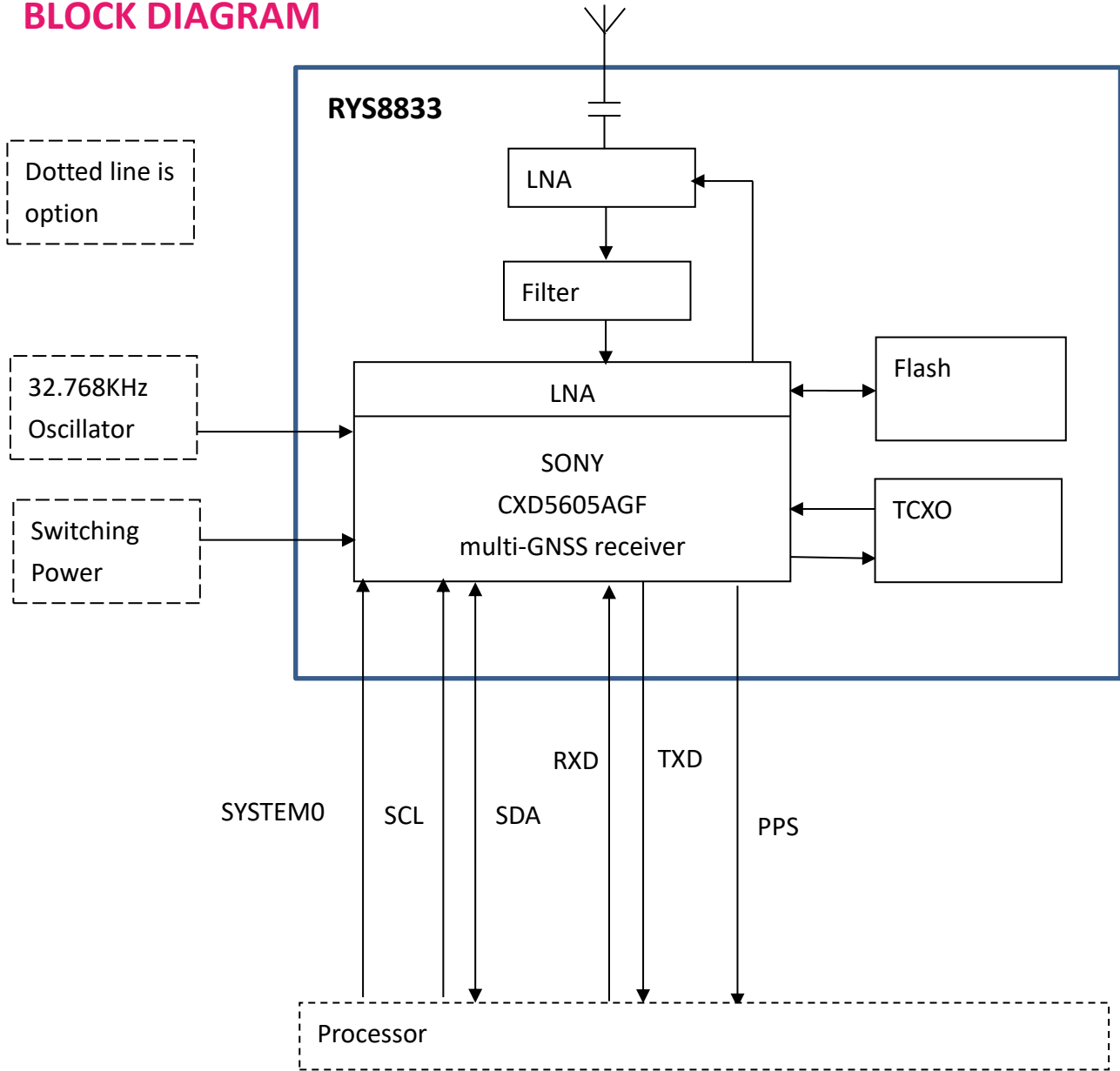

PIN DESCRIPTION

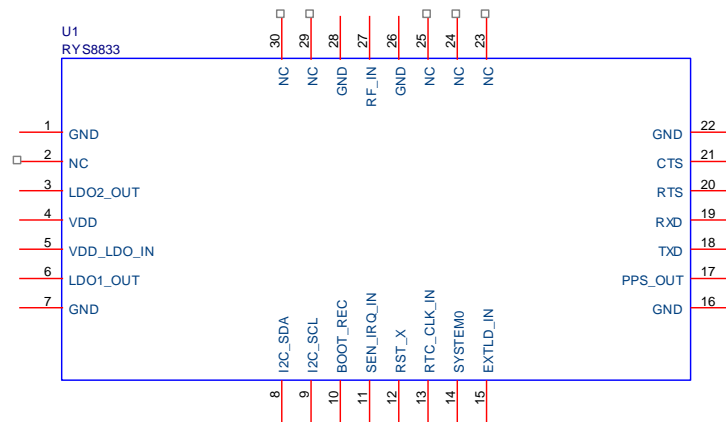

Pin	Name	I/O	Condition
1,7,16,22,26,28	GND	-	Ground
2,23,24,25,29,30	NC	-	Leave Unconnected.
3	LDO2_OUT	O	LDO output for memory core blocks.
4	VDD	I	Power Supply and I/O Voltage.
5	LDO_IN	I	LDO0 / LDO1 Input
6	LDO1_OUT	O	LDO output for digital block.
8	I2C_SDA	I/O	I2C SDA *If not used, Please Leave Unconnected.
9	I2C_SCL	I/O	I2C SCL *If not used, Please Leave Unconnected.
10	BOOT_REC	I/O	Reserved, Connect to GND.
11	SEN_IRQ_IN	I	Interrupt input. *If not used, Please Leave Unconnected.
12	RST_X	I	Reset input.
13	RTC_CLK_IN	I	RTC 32.768KHz clock input, The pin must be connected to GND, If not used.
14	SYSTEM0	I	VDD : UART Interface, GND : I2C Interface.
15	EXTLD_IN	I	Timing signal input, from LTE module. *If not used, Please Leave Unconnected.
17	PPS_OUT	O	Time pulse output.
18	TXD/SCL	O	Serial interface Output / I2C interface
19	RXD/SDA	I/O	Serial interface Input / I2C interface
20	Reversed	-	Leave Unconnected.
21	Reversed	-	Leave Unconnected.
27	RF_IN	I	GNSS RF Signal input.

APPLICATION SCHEMATIC (UART Interface)

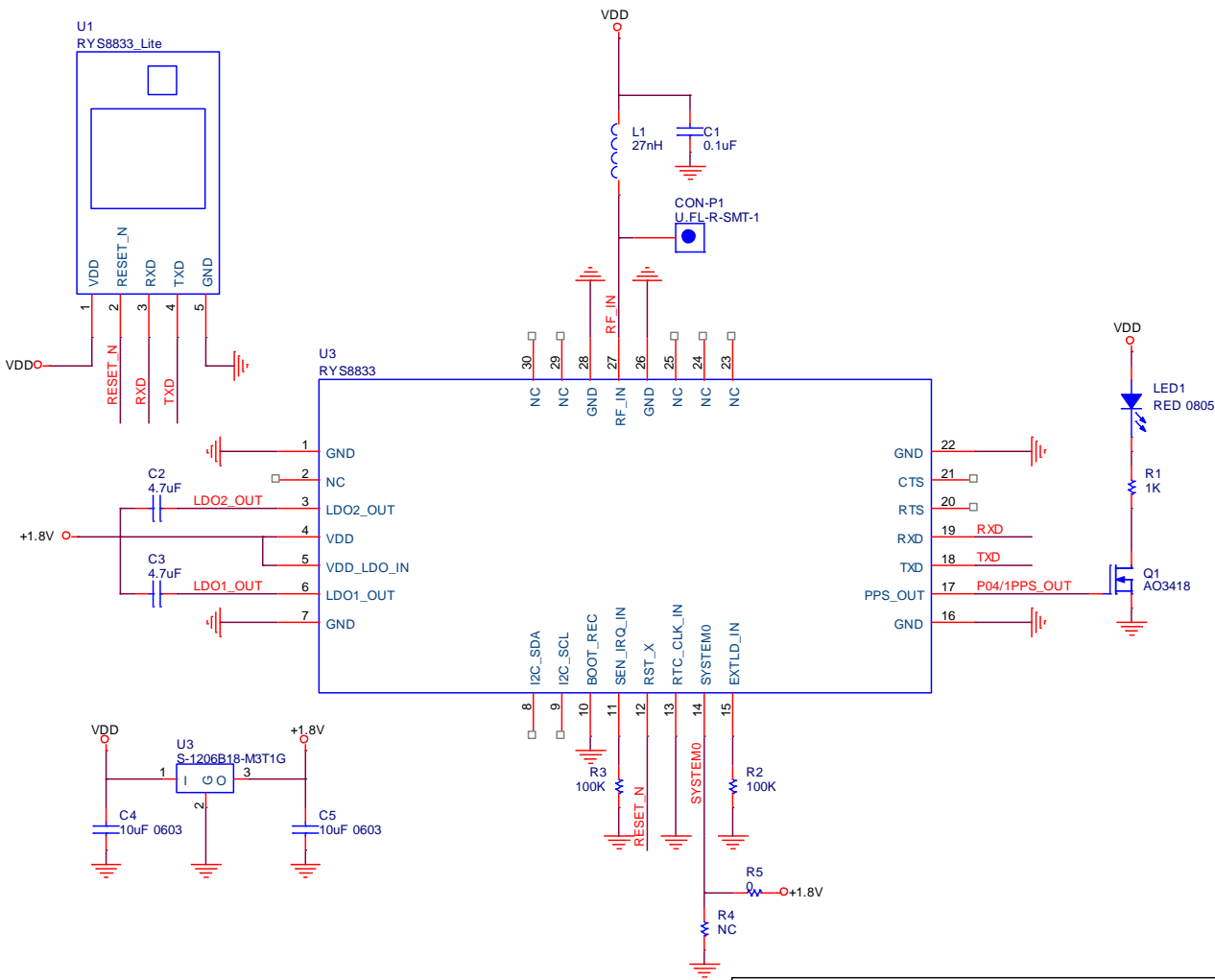

Title		
RYS8833_Lite		
Size	Document Number	Rev
Custom>Doc>		1.1
Date:	Tuesday, September 01, 2020	Sheet 1 of 1

APPLICATION SCHEMATIC (Use buck regulator)

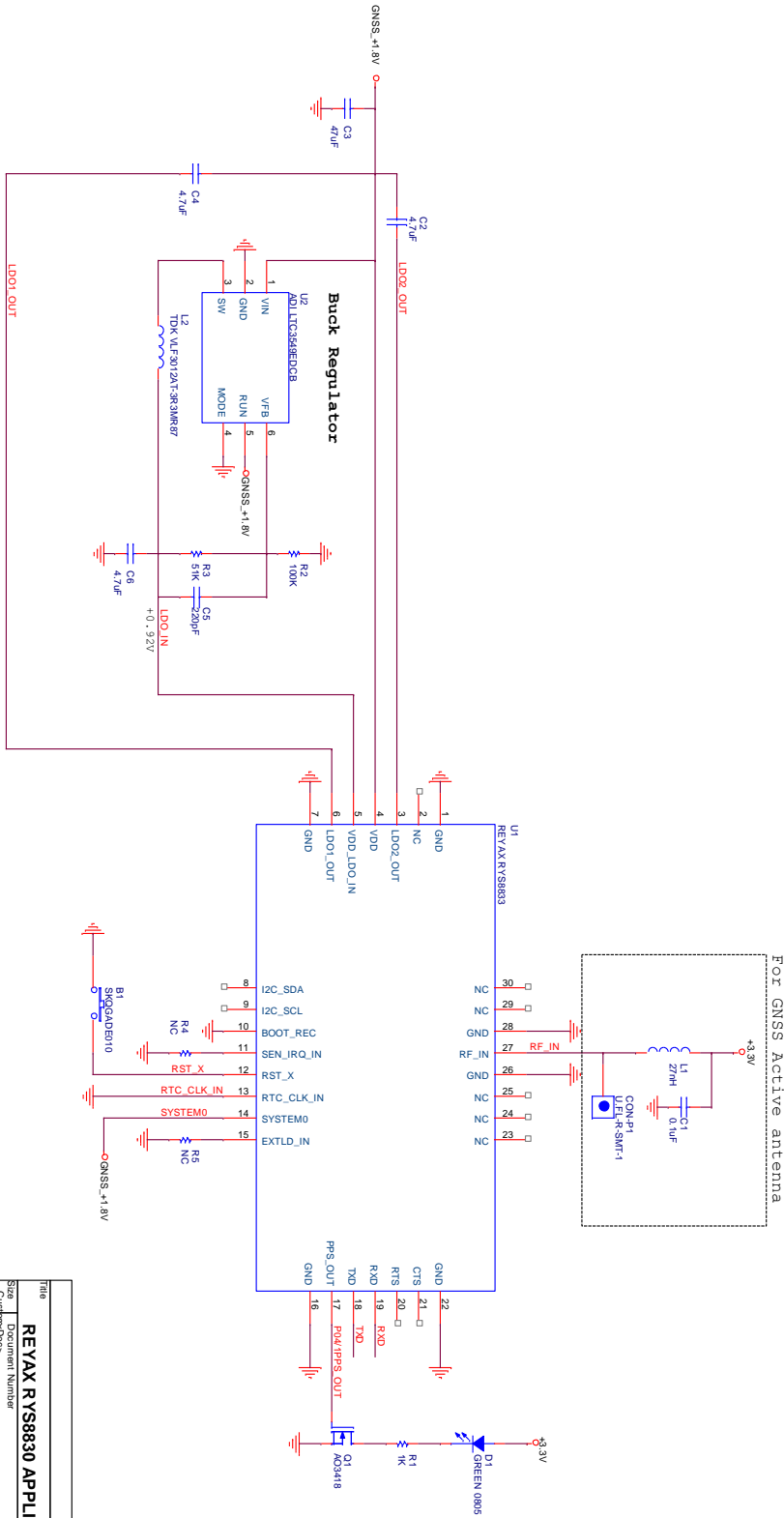

Title	REYAX RYS88330 APPLICATION
Size	Document Number
Version	0000000000
Date	Thursday, October 07, 2021
Sheet	1 of 1
Rev	1.0

SPECIFICATION

Item	Min.	Typical	Max.	Unit	Condition
Power Supply Voltage	1.71	1.8	1.89	V	VDD
	0.9	1.8	1.95	V	VDD_LDO_IN
GNSS continuous mode					
Satellite acquisition Current		19		mA	
Satellite tracking Current		13		mA	
Idle Current		3.7		mA	Waiting for command
Sleep2 mode current		0.2		mA	
Satellite acquisition Current		11.5		mA	Use buck regulator
Satellite tracking Current		8.2		mA	Use buck regulator
Idle Current		3.3		mA	Use buck regulator
Sleep0 mode current		0.5		mA	Use buck regulator
Sleep1 mode current		0.26		mA	Use buck regulator
Sleep2 mode current		0.26		mA	Use buck regulator
GNSS low power mode					
Satellite tracking average current	2.6		8.2	mA	Use buck regulator @GSOP command Sleep1 and normal mode cycle
I2C slave					I2C clock : 400kHz Address length : 7 bits Slave address : 0x24
Default Baud Rate		115200		bps	8,N,1
Digital input level high	0.7*VDD		VDD+0.3	V	VIH
Digital input level low	-0.3		0.3*VDD	V	VIL
Digital output level high	0.8*VDD		VDD	V	VOH 2mA
Digital output level low	0		0.2*VDD	V	VOL 2mA
Flash size		8		M-bit	
GNSS Center Frequency		1561.098 1575.42 1602.5625		MHz	BeiDou GPS Glonass
Navigation update rate		1		Hz	
Accuracy		1		M	Signal strength is -130dBm
Cold starts		35		Sec.	Signal strength is -130dBm
Hot starts		1		Sec.	
Tracking Sensitivity		-161		dBm	

Hot starts Sensitivity		-160		dBm	
Cold starts Sensitivity		-147		dBm	
Velocity		<0.1		m/s	The measured value is based on the condition of measured with simulator, and receiver moved at the constant speed (20km/h)
Operating Temperature	-40	25	+85	°C	
Dimensions					11mm*8mm*2.2mm
Weight		0.37		g	

REFLOW SOLDERING

Consider the "IPC-7530 Guidelines for temperature profiling for mass soldering (reflow and wave) processes, published 2001. **Only single reflow soldering processes are recommended for REYAX modules. Repeated reflow soldering processes and soldering the module upside down are not recommended.**

Preheat phase

Initial heating of component leads and balls. Residual humidity will be dried out. Please note that this preheat phase will not replace prior baking procedures.

- Temperature rise rate: max. 3 °C/s If the temperature rise is too rapid in the preheat phase it may cause excessive slumping.
- Time: 60 - 120 s If the preheat is insufficient, rather large solder balls tend to be generated. Conversely, if performed excessively, fine balls and large balls will be generated in clusters.
- End Temperature: 150 - 200 °C If the temperature is too low, non-melting tends to be caused in areas containing large heat capacity.

Heating/ Reflow phase

The temperature rises above the liquidus temperature of 217°C. Avoid a sudden rise in temperature as the slump of the paste could become worse.

- Limit time above 217 °C liquidus temperature: 40 - 60 s
- Peak reflow temperature: 245 °C

Cooling phase

A controlled cooling avoids negative metallurgical effects (solder becomes more brittle) of the solder and possible mechanical tensions in the products. Controlled cooling helps to achieve bright solder fillets with a good shape and low contact angle.

- Temperature fall rate: max 4 °C/s To avoid falling off, the REYAX module should be placed on the topside of the motherboard during soldering.

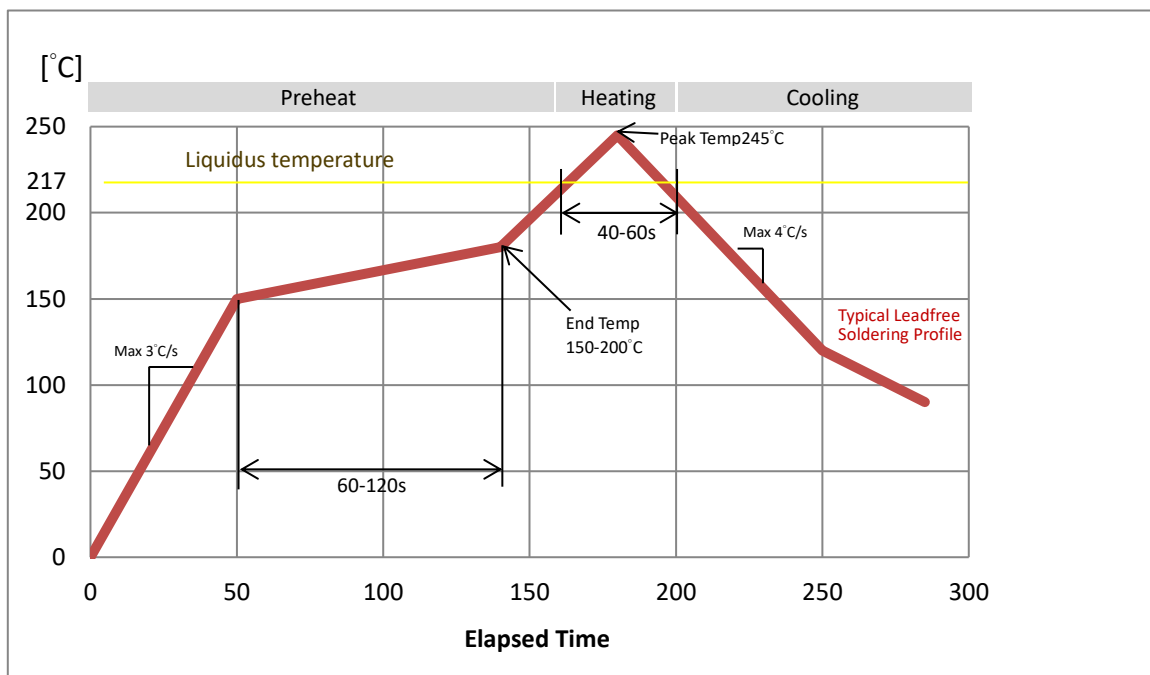

Recommended soldering profile

DIMENSIONS

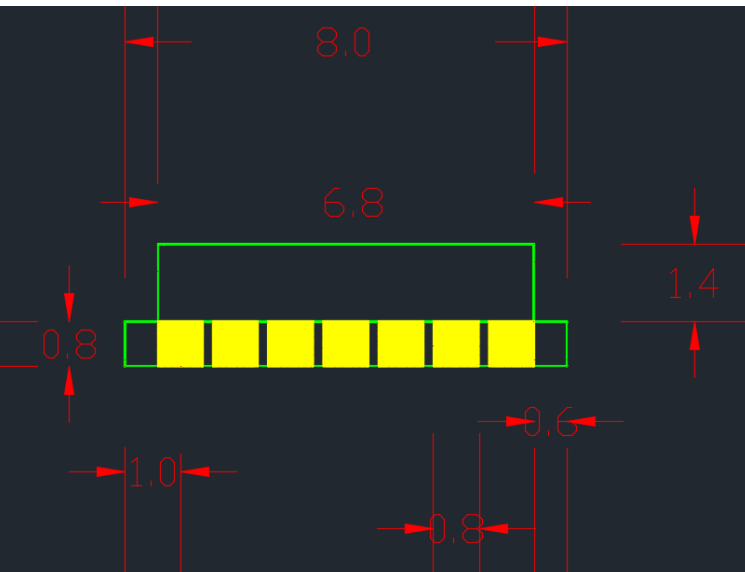
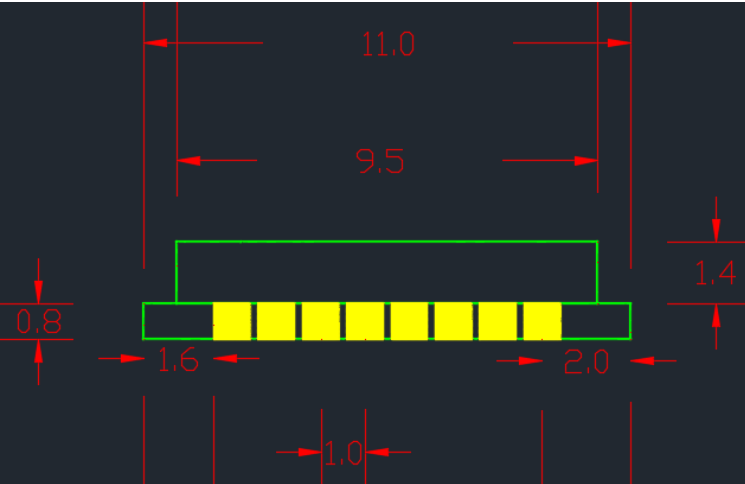
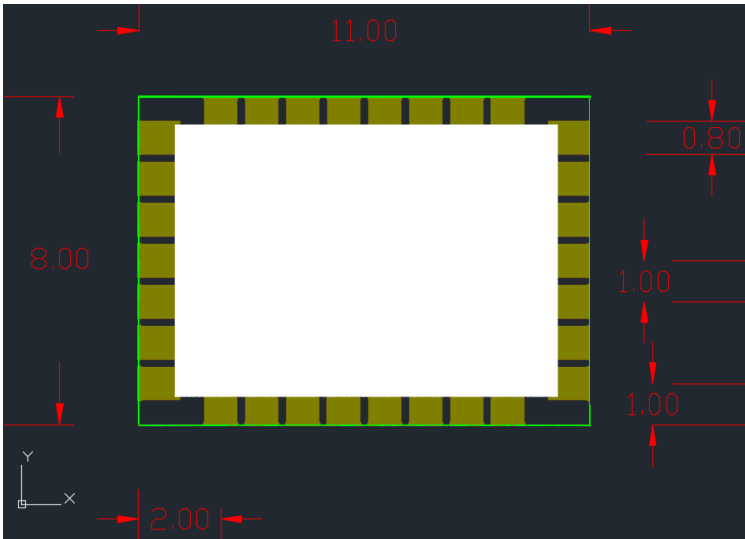

Unit : mm

LAYOUT FOOTPRINT RECOMMENDATIONS

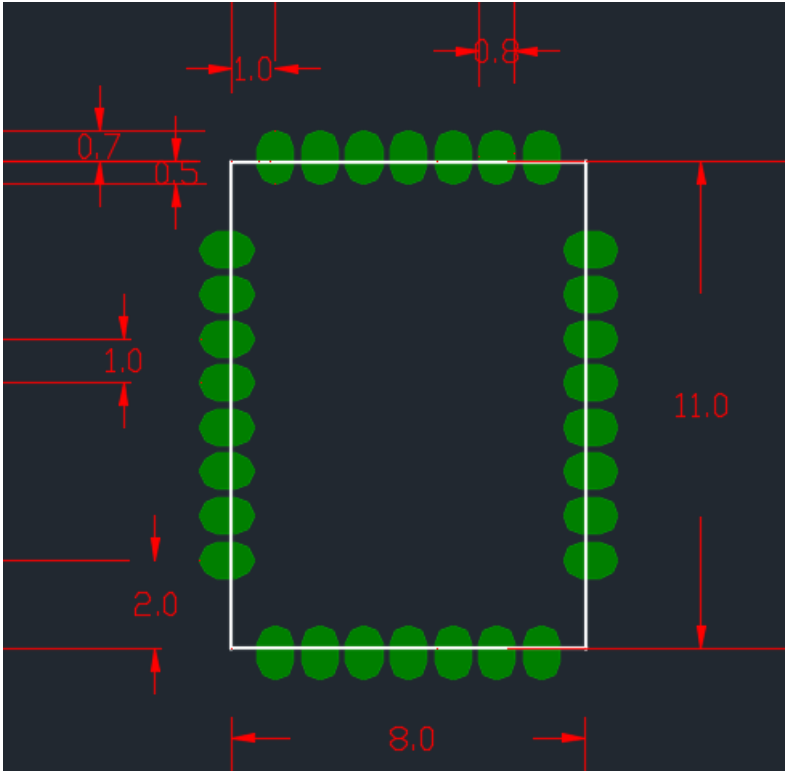

Unit : mm

GNSS Monitor software

STEP 1. INSTALL THE SOFTWARES

- 1.) Download the GNSS_Monitor2_ForCustomer_Setup(contact REYAX sales)

STEP 2. CONNECTION SETTING

Plug USB to TTL cable to connect the RYS8833_lite and the PC.

- 1.) Open the software GNSS_Monitor2_ForCustomer Target →RYS8833 select CXD5605
- 2.) Open the Serial Port setting
- 3.) Set the COM port number and the baud rate (Default is 115200bps).
- 4.) If connection successful, will show FW version message.

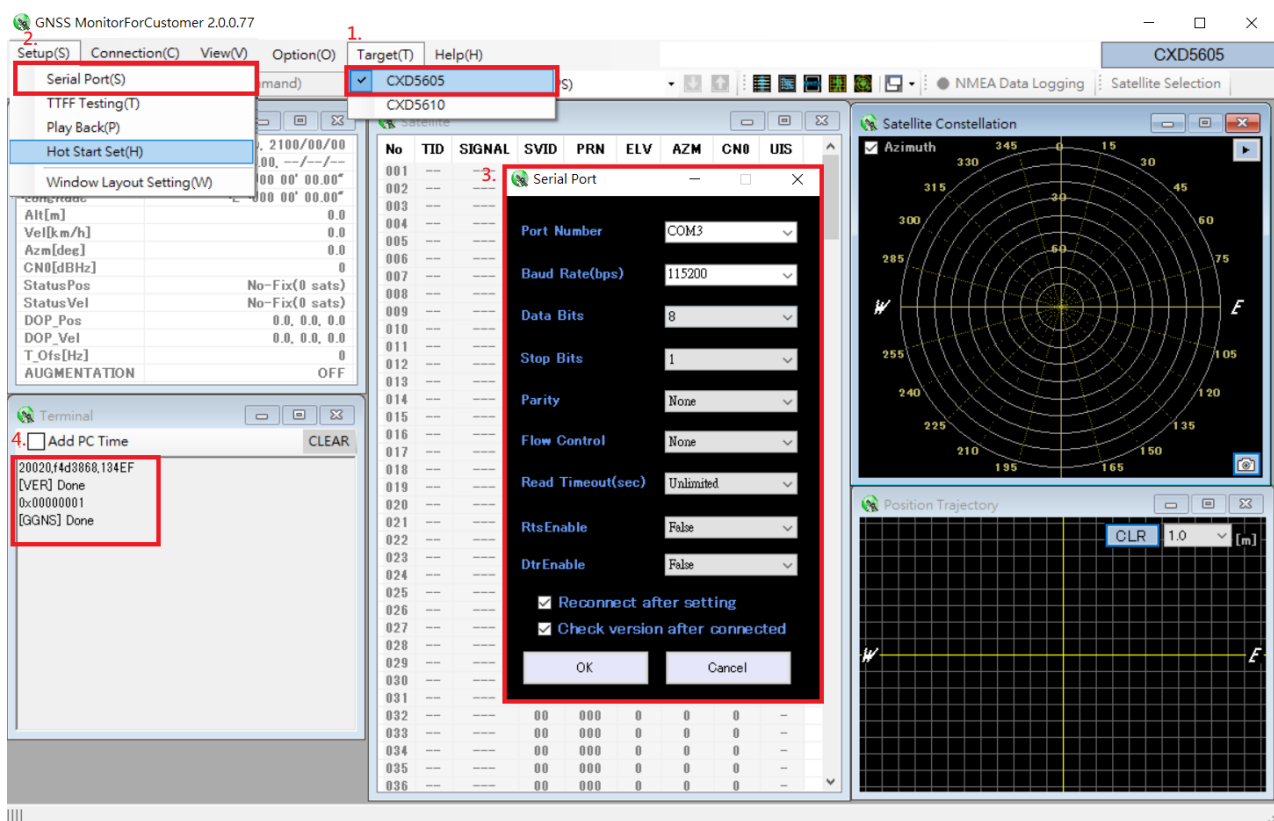

STEP 3. Command input setting

- 1.) Click "IDLE" button, Terminal window will show [GSTP]Done.
- 2.) Click "Satellite Selection" button, after select Satellite and click "Send". Terminal window will show [GNS]Done.
- 3.) Click "Hot start" button, Terminal window will show [GSR]Done. Module start output NMEA log.
- 4.) If want to stop tracking, click "IDLE" button.

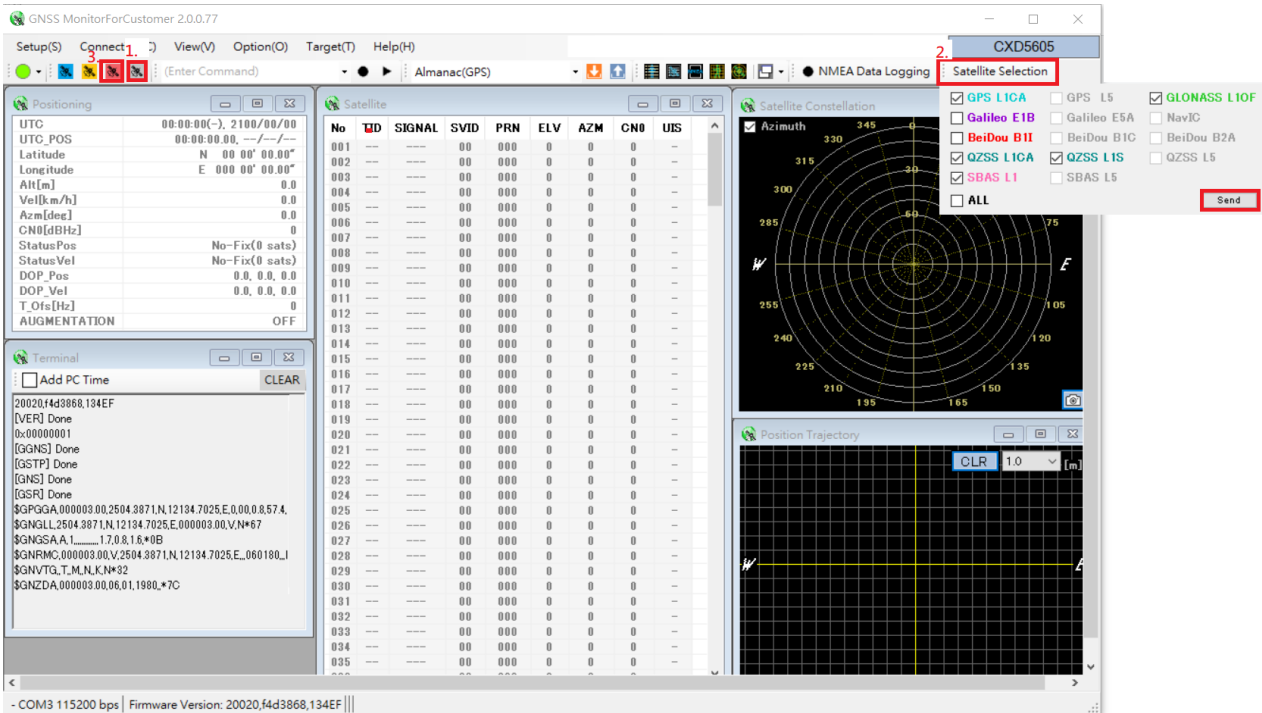

*For detailed command user guide, please refer to RYS8830_RYS8833_Software_Guide

QUICK START GUIDE

STEP 1. Power on module

STEP 2. Issue command

- 1.) @GSTP // Positioning stop
- 2.) @GNS 47 // Positioning-use satellite use GPS + GLONASS + SBAS + QZSS L1-CA + QZSS L1-S
- 3.) @GTIM 2022 12 20 00 00 00 // inject UTC time
- 4.) @GPPS 1 // enable 1PPS function
- 5.) @GSR // hot start

*For detailed command user guide, please refer to RYS8830_RYS8833_Software_Guide