

# **RYRR20I**

**Multiprotocol Fully  
Integrated 13.56MHz  
RFID Module**

**Datasheet**

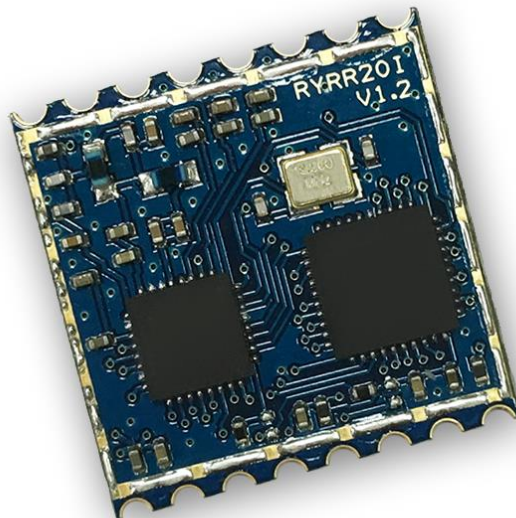

## PRODUCT DESCRIPTION

The RYRR20I module is a 13.56-MHz RFID. Built-in programming options make the device suitable for a wide range of applications for proximity and vicinity identification systems.

## FEATURES

- Completely Integrated Protocol Handling for ISO15693, ISO18000-3, ISO14443A/B, NFCIP-1 (ISO/IEC 18092) and FeliCa.
- Integrated Encoders, Decoders, Active and Passive Target Operation for All Three Bit Rates (106 kbps, 212 kbps, 424 kbps) and Card Emulation.
- RF Field Detector.
- Integrated State Machine for ISO14443A Anti-collision (Broken Bytes)
- TI TRF7970A RFID Engine.
- Operation Temperature range: -40 to +85°C.

## APPLICATIONS

- RFID cards Reader
- EV charger
- Mobile Devices (Tablets, Handsets)
- Secure Pairing (Bluetooth, Wi-Fi, Others)
- Public Transport or Event Ticketing

## SPECIFICATION

Item	Min.	Typical	Max.	Unit	Condition
Operation Voltage	3	3.3	3.6	V	VDD
V <sub>OH</sub> VDD=3.3V	2.5	3	3.3	V	TXD High-level output voltage
V <sub>OL</sub> VDD=3.3V	0	0.3	0.7	V	TXD Low-level output voltage
V <sub>IH</sub> VDD=3.3V	2.5	3.3	3.3	V	RXD High-level input voltage
V <sub>IL</sub> VDD=3.3V	0	0	0.7	V	RXD Low-level input voltage
RF Output Power		20	23	dBm	
RF transmit current		90		mA	
Communication Range		5		cm	Standard card
Reset Time	50	60	70	ms	
Baud Rate		115200		bps	8,N,1
RF Frequency Range	13.553	13.56	13.567	MHz	
Operating Temperature	-40	25	+85	°C	
Antenna					External
Dimensions					20mm*20mm*2.4mm
Weight		2		g	

## PIN DESCRIPTION

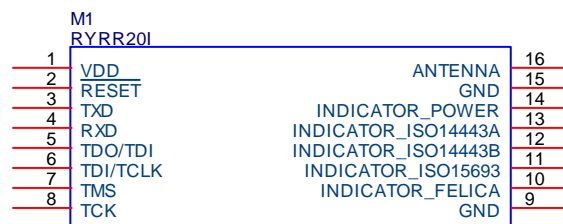

Pin	Name	I/O	Condition
1	VDD	I	Power Supply
2	RESET	I	Low reset
3	TXD	O	UART Data Output
4	RXD	I	UART Data Input
5	TDO/TDI	-	Leave Unconnected.
6	TDI/TCLK	-	Leave Unconnected.
7	TMS	-	Leave Unconnected.
8	TCK	-	Leave Unconnected.
9	GND	-	Ground
10	INDICATOR_FELICA	O	High generated by the module after it detect FELICA
11	INDICATOR_ISO15693	O	High generated by the module after it detect ISO15693
12	INDICATOR_ISO14443B	O	High generated by the module after it detect ISO14443B
13	INDICATOR_ISO14443A	O	High generated by the module after it detect ISO14443A
14	INDICATOR_POWER	O	INDICATOR_POWER
15	GND	-	Ground
16	ANTENNA	I/O	RF Signals input/output

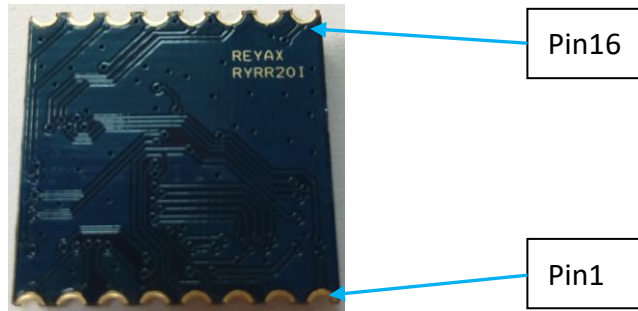

## EVB APPLICATION CIRCUIT

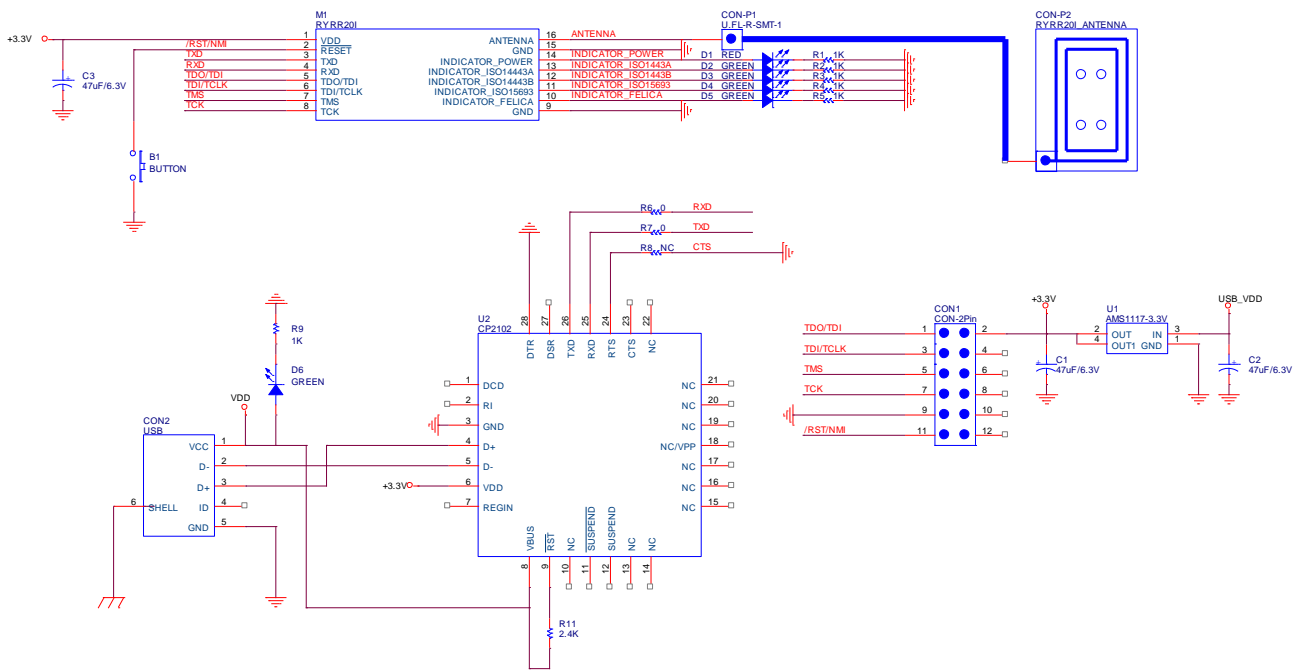

Title		
<b>REYAX RYRR201_EVB</b>		
Size	Document Number	Rev
Custom-Doc		1.2
Date:	Tuesday, August 23, 2016	Sheet 1 of 1

# REFLOW SOLDERING

Consider the "IPC-7530 Guidelines for temperature profiling for mass soldering (reflow and wave) processes, published 2001. **Only single reflow soldering processes are recommended for REYAX modules. Repeated reflow soldering processes and soldering the module upside down are not recommended.**

## Preheat phase

Initial heating of component leads and balls. Residual humidity will be dried out. Please note that this preheat phase will not replace prior baking procedures.

- Temperature rise rate: max. 3 °C/s If the temperature rise is too rapid in the preheat phase it may cause excessive slumping.
- Time: 60 - 120 s If the preheat is insufficient, rather large solder balls tend to be generated. Conversely, if performed excessively, fine balls and large balls will be generated in clusters.
- End Temperature: 150 - 200 °C If the temperature is too low, non-melting tends to be caused in areas containing large heat capacity.

## Heating/ Reflow phase

The temperature rises above the liquidus temperature of 217°C. Avoid a sudden rise in temperature as the slump of the paste could become worse.

- Limit time above 217 °C liquidus temperature: 40 - 60 s
- Peak reflow temperature: 245 °C

## Cooling phase

A controlled cooling avoids negative metallurgical effects (solder becomes more brittle) of the solder and possible mechanical tensions in the products. Controlled cooling helps to achieve bright solder fillets with a good shape and low contact angle.

- Temperature fall rate: max 4 °C/s To avoid falling off, the REYAX module should be placed on the topside of the motherboard during soldering.

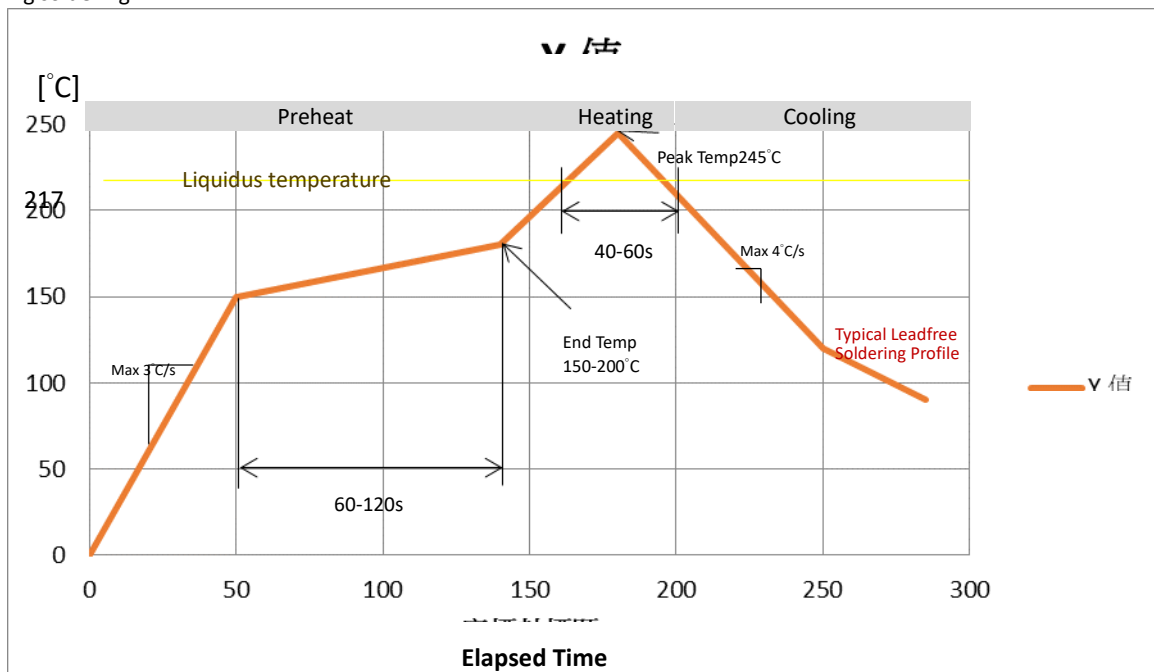

**Recommended soldering profile**

## DIMENSIONS

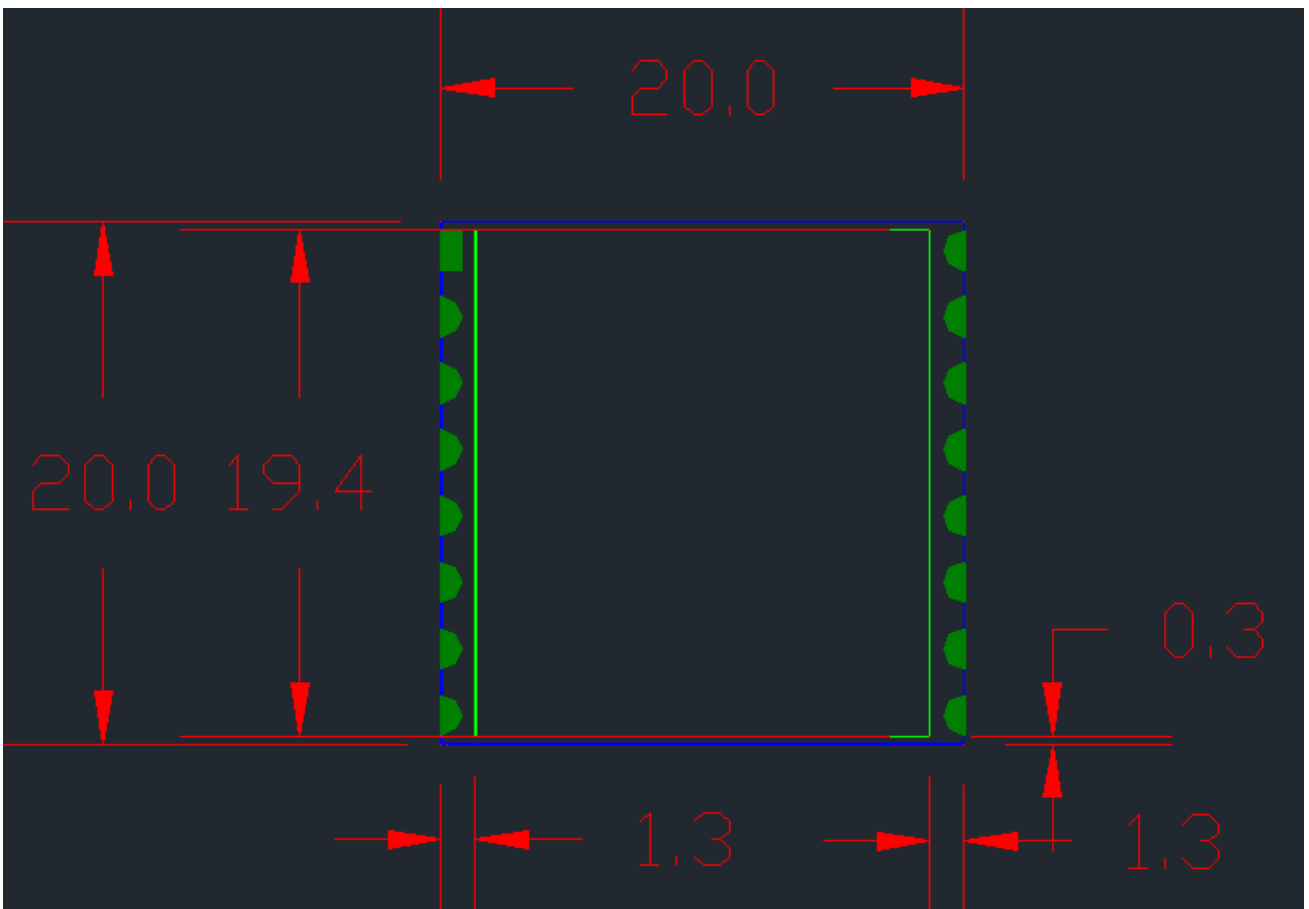
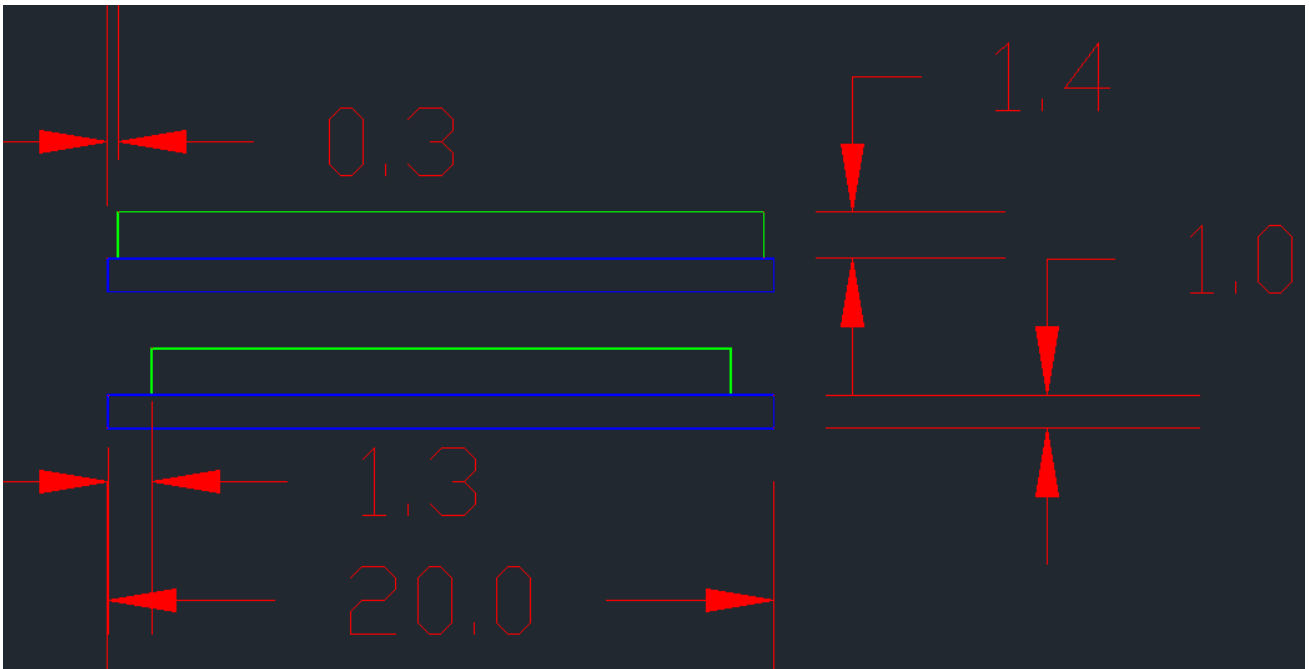

unit : mm

## LAYOUT FOOTPRINT RECOMMENDATIONS

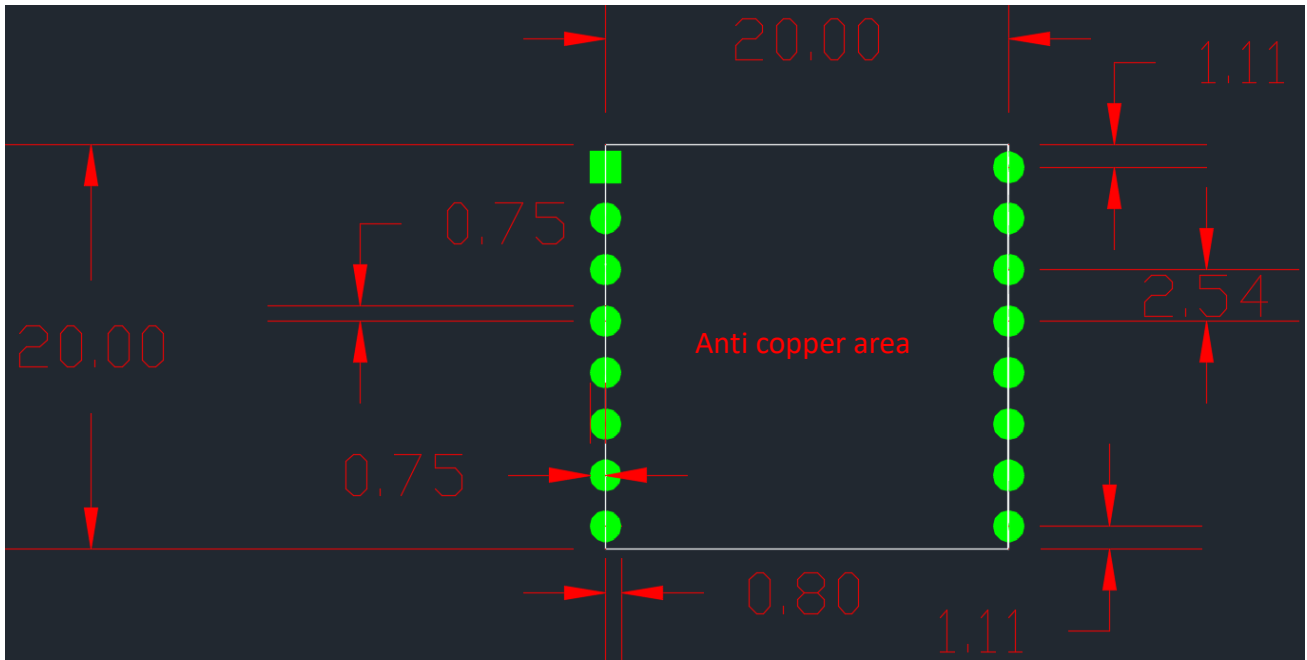

unit : mm

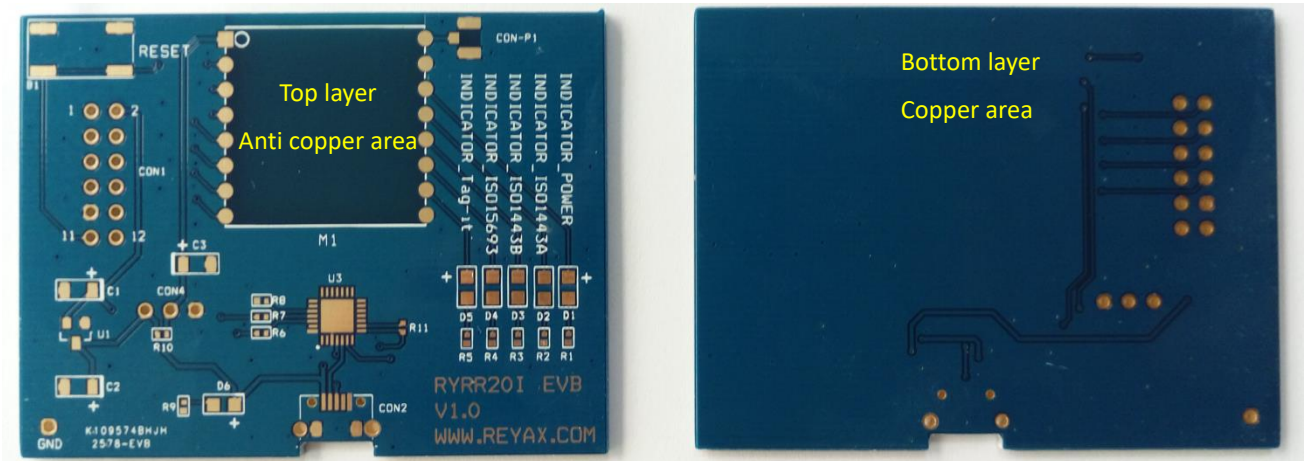



## RYRR20I ANTENNA REFERENCE

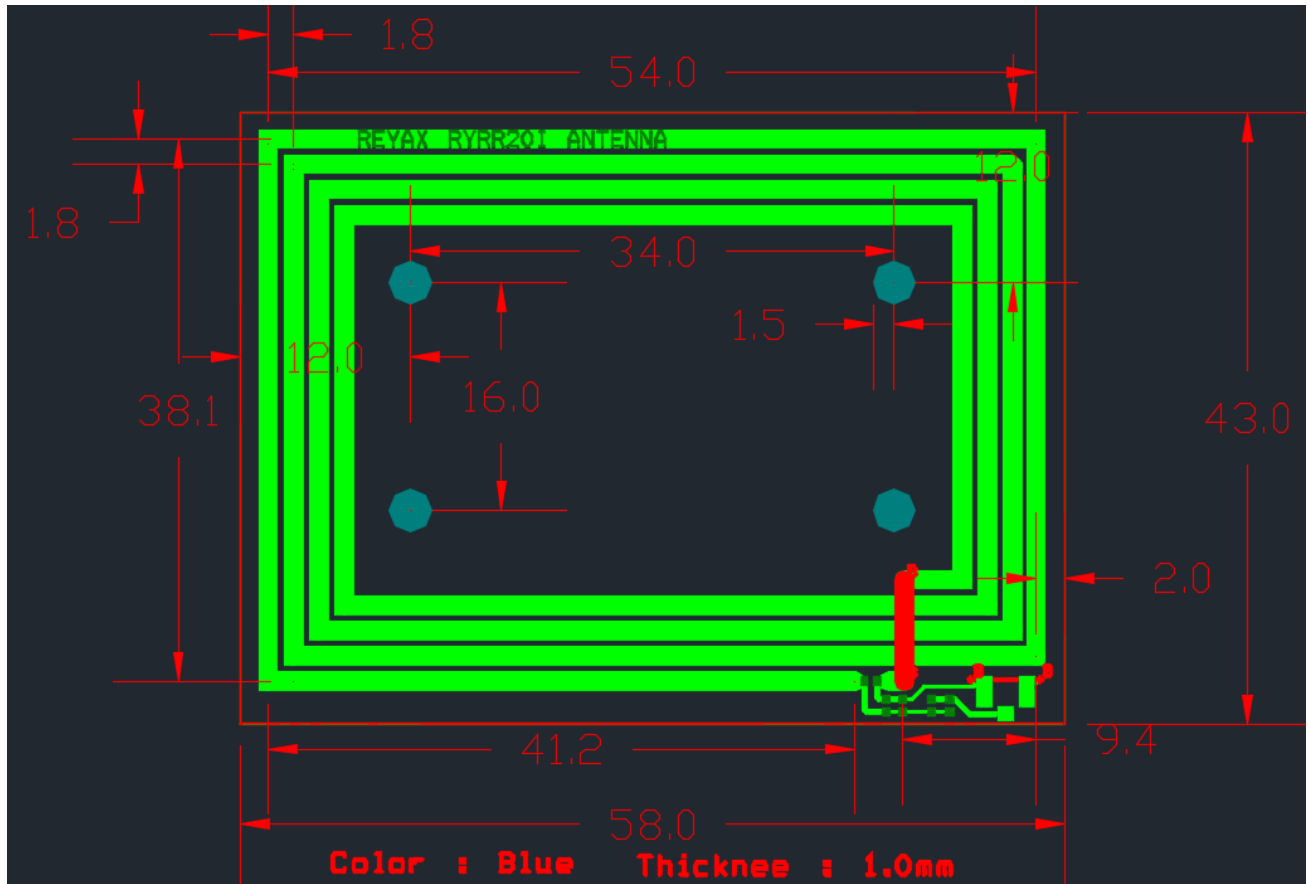

Trace Width=1.3mm, Trace Spacing=0.5mm, PCB thickness=1.6mm 1oz, Material=FR4, Layer=2  
unit : mm

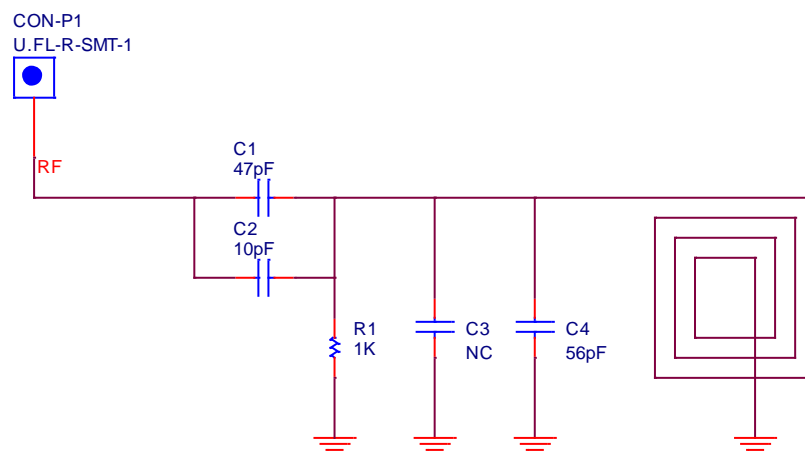

## STANDALONE MODE DESCRIPTION

The RYRR20I has a standalone mode in which when power is applied, then the preloaded MCU firmware initializes the RFID IC for full power operation, the INDICATOR\_POWER pin become high, and begins a polling loop for ISO15693, ISO14443A, and ISO14443B transponders.

When any (or all) of these types of transponders are presented to the onboard antenna, the corresponding INDICATOR\_ISO pin become high.

Syntax	Output
After RESET	REYAX RYRR20I Vx.x

Output Format	Output Examples
<p>&lt;ISO&gt; [&lt;UID&amp; data&gt;,&lt;RSSI&gt;]0x0D 0x0A</p> <p>&lt;ISO&gt; is the types of transponders:</p> <p>ISO14443A</p> <p>ISO14443B</p> <p>ISO15693</p> <p>FELICA</p> <p>&lt;UID&amp; data&gt; is the User Identification and data</p> <p>&lt;RSSI&gt; is the Received Signal Strength Indicator, show in 2 bytes hexadecimal, Maximum is 0x7F</p>	<p>ISO14443A[0424B018425F1D8080,6C]</p> <p>ISO14443A[0424B018425F1D8080,6D]</p> <p>ISO14443A[0001810293,40]</p> <p>ISO14443B[500020F52C00000000808144,75]</p> <p>ISO14443A[0001810293,40]</p> <p>ISO15693[10167B0F500104E0,63]</p> <p>FELICA[1201012E3D23BA06527700F1000000014300,47]</p> <p>ISO15693[45998550800204E0,65]</p>

## STANDALONE MODE APPLICATION TEST

Run the free Hyper-terminal software for Windows, *Access Port*, please download by the following link.

<http://www.sudt.com/en/ap/>

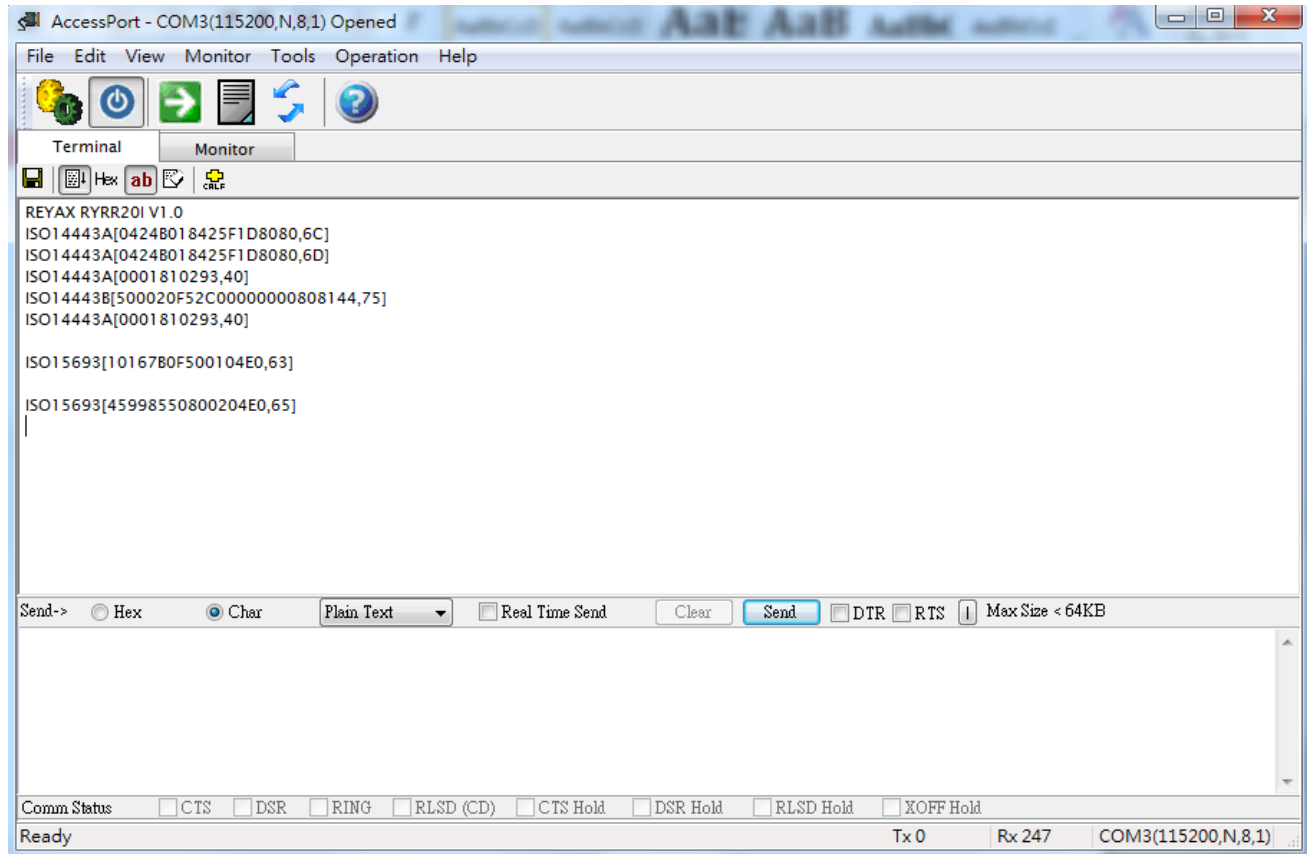

## ISO15693 COMMAND MODE

The RYRR20I will enter the ISO15693 command mode after the RXD receive the string 0108000304FF0000. Please refer to the ISO15693 command guide. If you want to exit the ISO15693 command mode, please reset the RYRR20I.

## EVALUATION KIT FOR RYRR201

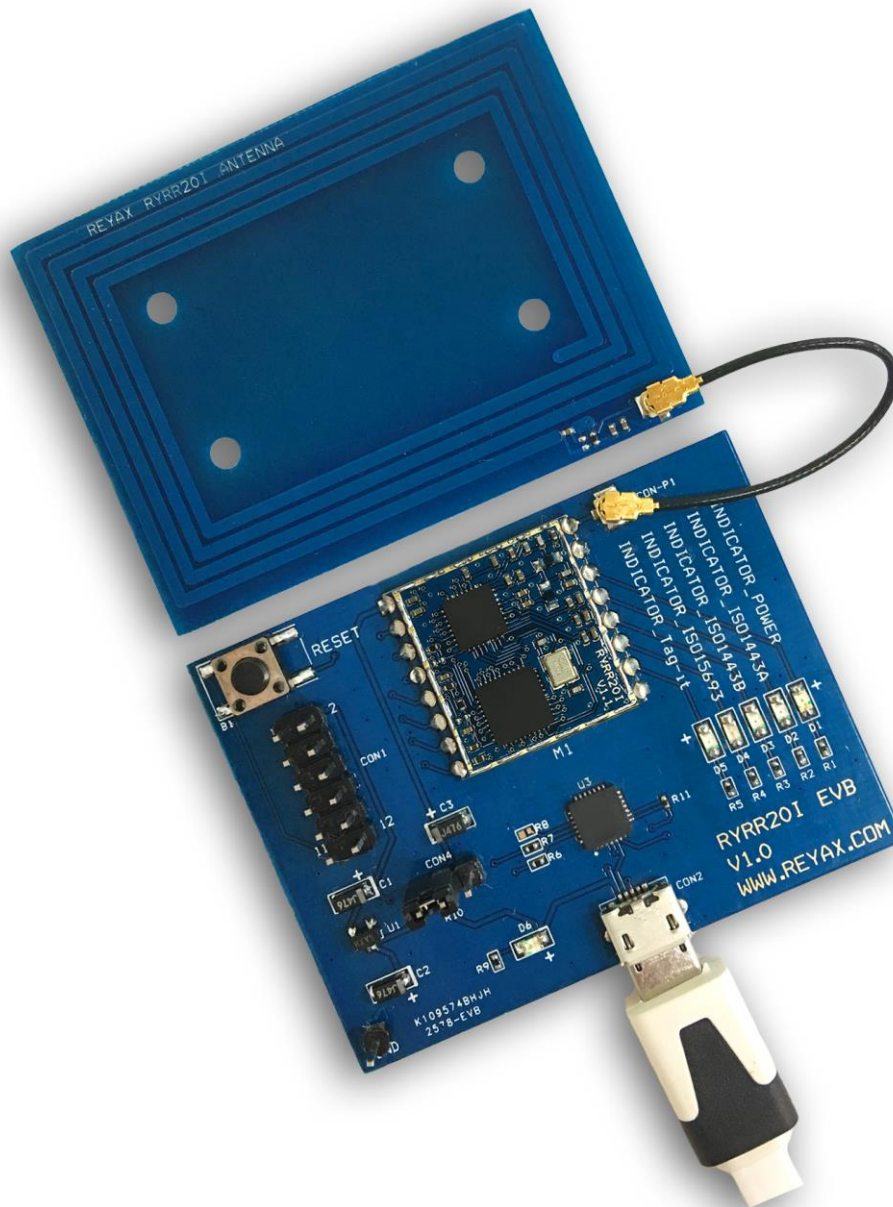

**REYAX**  
TECHNOLOGY CORPORATION, LTD

E-mail : [sales@reyax.com](mailto:sales@reyax.com)

Website : <http://reyax.com>