

RYRR10S

**Multiprotocol Fully
Integrated 13.56MHz
RFID & NFC Antenna Module**

Datasheet



PRODUCT DESCRIPTION

The RYRR10S antenna module is a 13.56-MHz RFID and Near Field Communication (NFC) system. Built-in programming options make the device suitable for a wide range of applications for proximity and vicinity identification systems.

FEATURES

- ST CR95HF NFC/RFID Engine.
- Supports Near Field Communication (NFC) ISO/IEC 18092.
- Completely Integrated Protocol Handling for ISO/IEC 15693, ISO/IEC 14443A, ISO/IEC 14443B.
- NXP MIFARE® Classic compatible
- Designed with PCB integrated antenna.
- UART / SPI Interface optional.



SPECIFICATION

Item	Min.	Typical	Max.	Unit	Condition
Operation Voltage	2.7		5.5	V	VDD
V _{OH}	0.9*VDD	VDD	VDD	V	TXD High-level output voltage
V _{OL}	0	0	0.1*VDD	V	TXD Low-level output voltage
V _{IH}	0.7*VDD	3.3	VDD	V	RXD High-level input voltage
V _{IL}	0	0	0.3*VDD	V	RXD Low-level input voltage
RF Output Power		55		mW	VDD=3V
Reader mode current		70		mA	VDD=3V
Ready state current		2.5		mA	VDD=3V
Tag detect mode current		50	100	uA	4 RF bursts per second
Sleep state current		20	80	uA	
Communication Range		4	8	cm	Depending on the RFID TAG.
Startup time		6		ms	
Baud Rate		57600		bps	8,N,1
RF Frequency Range	13.553	13.56	13.567	MHz	
Operating Temperature	-25	25	+85	°C	
Antenna					Internal
Weight		3.64		g	

*For more detail, please refer to the ST CR95HF information.

BLOCK DIAGRAM

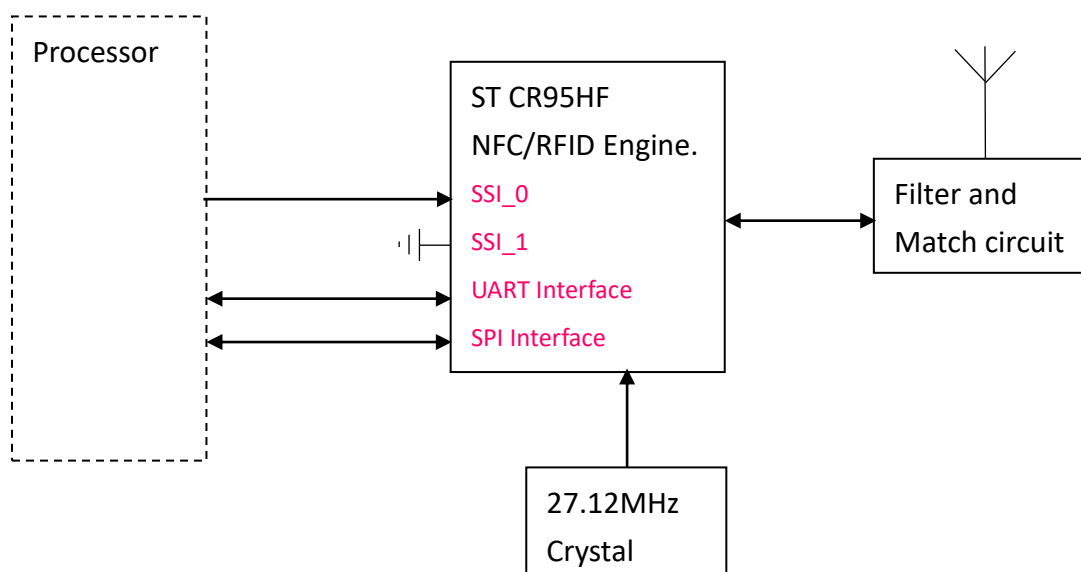

PIN DESCRIPTION

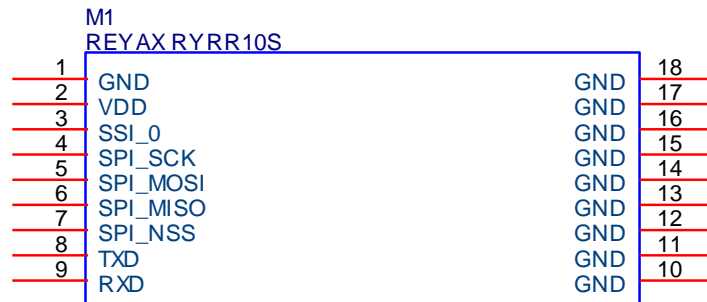

Pin	Name	I/O	Condition
1	GND	P	Ground
2	VDD	P	Main power supply
3	SSI_0	I	Select serial communication interface UART: 0 SPI: 1
4	SPI_SCK	I	SPI serial clock
5	SPI_MOSI	I	SPI Data, Slave Input
6	SPI_MISO	O	SPI Data, Slave Output
7	SPI_NSS	I	SPI Slave Select (active low)
8	TXD	O	UART Data Output
9	RXD	I	UART Data Input
10	GND	P	Ground
11	GND	P	Ground
12	GND	P	Ground
13	GND	P	Ground
14	GND	P	Ground
15	GND	P	Ground
16	GND	P	Ground
17	GND	P	Ground
18	GND	P	Ground



APPLICATION SCHEMATIC

UART INTERFACE

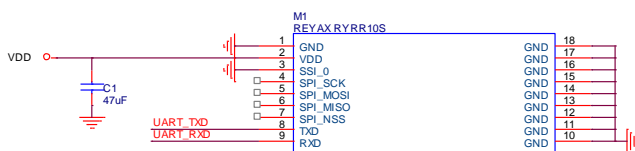

SPI INTERFACE

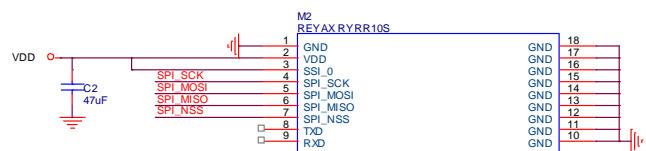

PCB LAYOUT GUIDE

- [1] Avoid placing any metal material between the RYRR10S and the RFID TAG.
- [2] The height >1mm components and any metal material should be placed at least 5 mm away from the RYRR10S.
- [3] The minimum distance between the plastic cover and the RYRR10S should be 1mm.
- [4] Keep the VDD voltage ripple under 30mVpp.
- [5] PCB layout reference:

Antenna area,
Reduce metal materials
as you can.

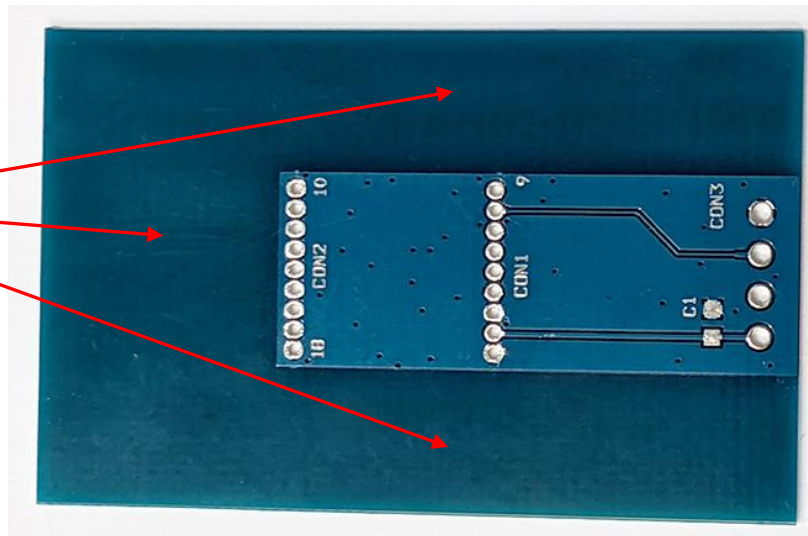

- [6] RYRR10S assembled state:

RFID TAG sensing area

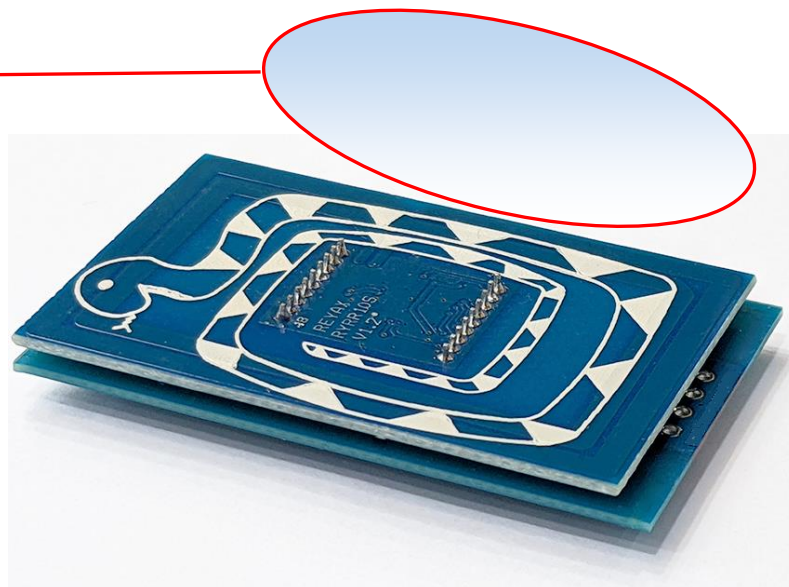

DIMENSIONS

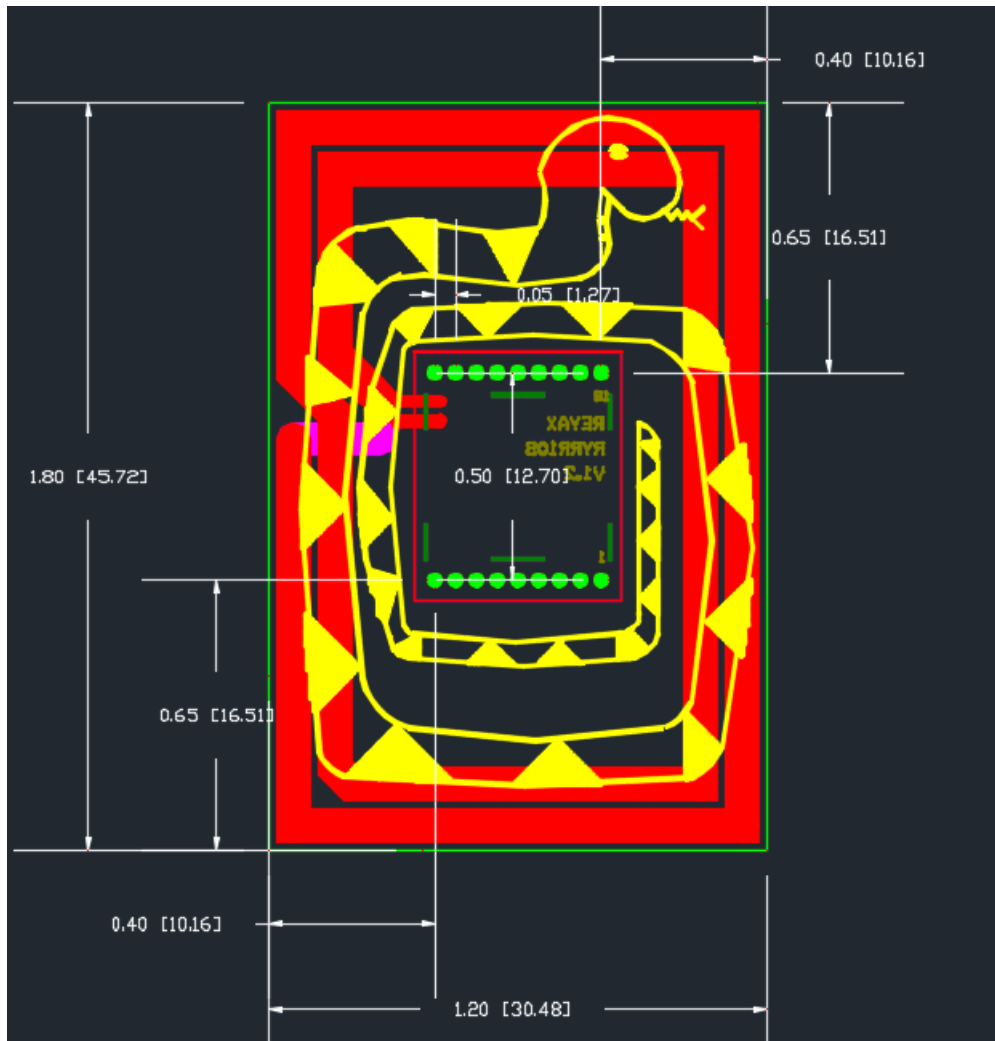

unit : inch[mm]

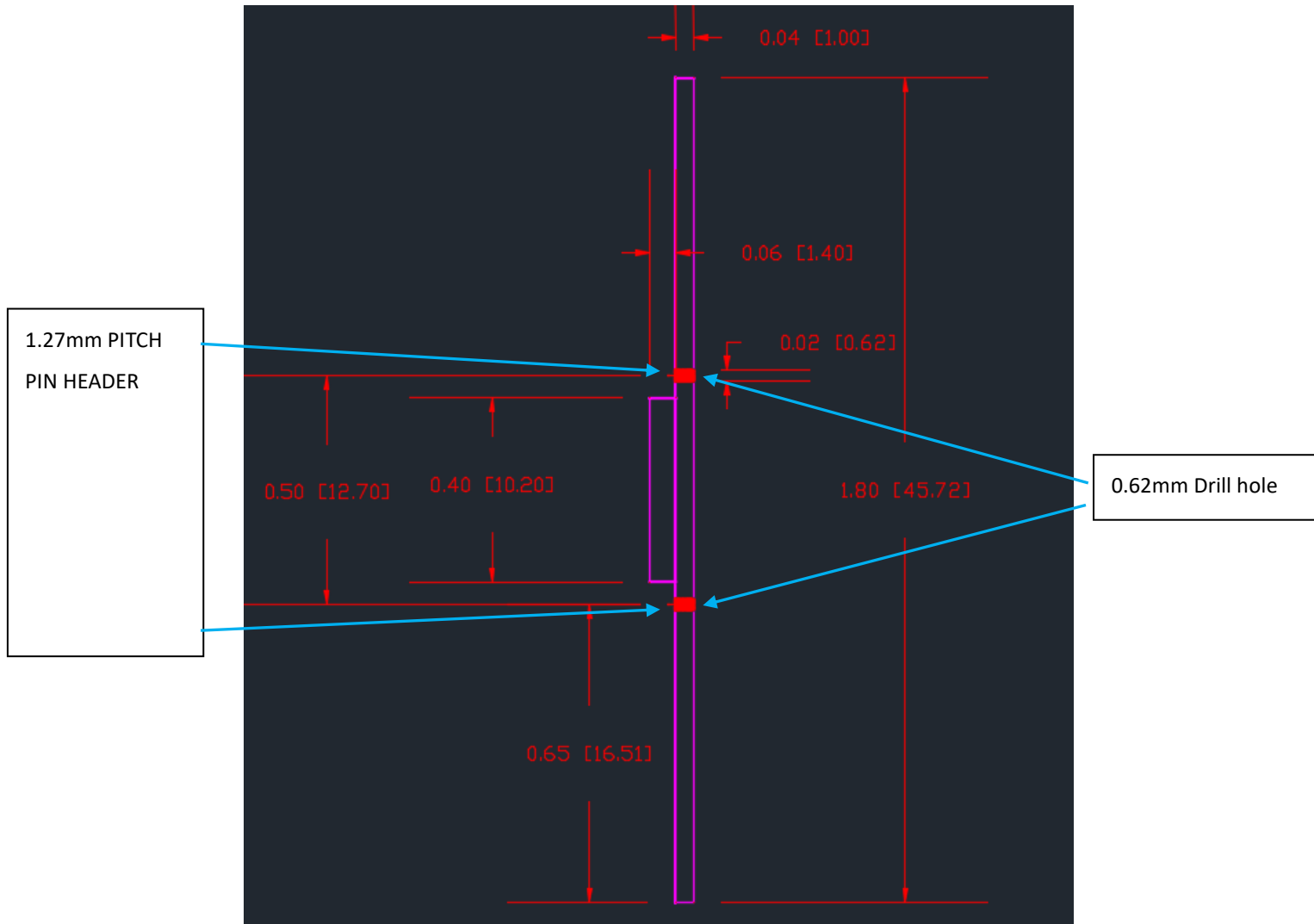

unit : inch[mm]

1.27mm PITCH PIN HEADER

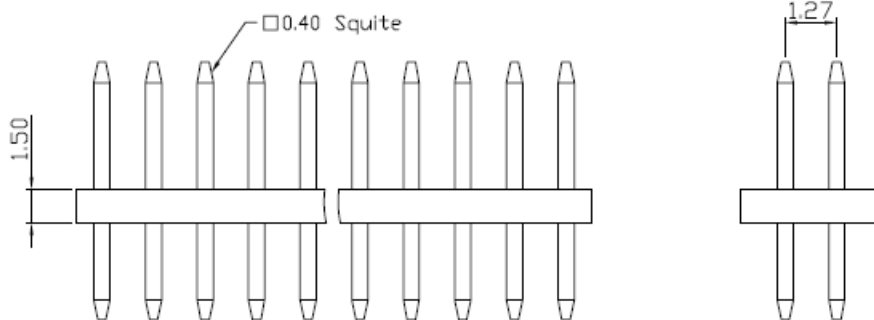

unit : mm

FIRMWARE QUICK START GUIDE

Host to RYRR10S command is in **blue**.

The RYRR10S response is in **red**.

Example1 : ISO/IEC 14443A ultralight Read UID and Read/Write Block Command in HEX.

//The ECHO command verifies the possibility of communication between a Host and the RYRR10S.

>>> 55

<<< 55

//Protocol select 14443A

>>> 02 02 02 00

<<< 00 00

//Optimization of synchronization between digital and analog inputs by adjusting TimerW value

>>> 09 04 3A 00 58 04

<<< 00 00

//write modulation and gain

>>> 09 04 68 01 01 D3

<<< 00 00

//REQAreply ATQA

>>> 04 02 26 07

<<< 80 05 44 00 28 00 00

44 00 = ATQA

//ISO14443-A ANTICOL 1

>>> 04 03 93 20 08

<<< 80 08 88 04 1C C7 57 28 00 00

88 04 1C C7 = ANTICOL 1

//ISO14443-A SELECT 1

>>> 04 08 93 70 88 04 1C C7 57 28

04 = send receive command sent to the RYRR10S

08 = length

93 70 = data

88 04 1C C7 = fill in ANTICOL 1 get from the previous command response

<<< 80 06 04 DA 17 08 00 00

//ISO14443-A ANTICOL 2

>>> 04 03 95 20 08

<<< 80 08 82 3F 75 81 49 28 00 00

82 3F 75 81 = ANTICOL 2

//ISO14443-A SELECT 2

>>> 04 08 95 70 82 3F 75 81 49 28

04 = send receive command sent to the RYRR10S

08 = length

95 70 = data

82 3F 75 81 = fill in ANTICOL 2 get from the previous command response

<<< 80 06 00 FE 51 08 00 00

<ANTICOL 1>< ANTICOL 2> = UID = 04 1C C7 82 3F 75 81

//WRITE @07 data A5 A5 A5 A5

>>> 04 07 A2 07 A5 A5 A5 A5 28

04 = send receive command sent to the RYRR10S

07 = length

A2 = write command

07 = block number

A5 A5 A5 A5 = Data

<<< 87 00

//READ @07

>>> 04 03 30 07 28

04 = send receive command sent to the RYRR10S

03 = length

30 = read command

07 = block number

<<< 80 15 A5 A5 A5 A5 00 00 00 00 00 00 00 00 00 00 00 00 47 5C 08 00 00

A5 A5 A5 A5 = Data

```

2022/7/8 13:22:37.952 [TX] - 55
2022/7/8 13:22:37.964 [RX] - 55
2022/7/8 13:22:41.557 [TX] - 02 02 02 00
2022/7/8 13:22:41.558 [RX] - 00 00
2022/7/8 13:22:43.522 [TX] - 09 04 3A 00 58 04
2022/7/8 13:22:43.523 [RX] - 00 00
2022/7/8 13:22:45.241 [TX] - 09 04 68 01 01 D3
2022/7/8 13:22:45.243 [RX] - 00 00
2022/7/8 13:22:46.945 [TX] - 04 02 26 07
2022/7/8 13:22:46.947 [RX] - 80 05 44 00 28 00 00
2022/7/8 13:22:50.100 [TX] - 04 03 93 20 08
2022/7/8 13:22:50.103 [RX] - 80 08 88 04 1C C7 57 28 00 00
2022/7/8 13:22:55.289 [TX] - 04 08 93 70 88 04 1C C7 57 28
2022/7/8 13:22:55.293 [RX] - 80 06 04 DA 17 08 00 00
2022/7/8 13:22:58.196 [TX] - 04 03 95 20 08
2022/7/8 13:22:58.198 [RX] - 80 08 82 3F 75 81 49 28 00 00
2022/7/8 13:23:02.436 [TX] - 04 08 95 70 82 3F 75 81 49 28
2022/7/8 13:23:02.439 [RX] - 80 06 00 FE 51 08 00 00
2022/7/8 13:23:31.330 [TX] - 04 03 30 07 28
2022/7/8 13:23:31.334 [RX] - 80 15 00 00 00 00 00 00 00 00 00 00 00 00 00 00 00 00 00 00 37 49 08 00 00
2022/7/8 13:23:52.332 [TX] - 04 07 A2 07 A5 A5 A5 A5 28
2022/7/8 13:23:52.336 [RX] - 87 00
2022/7/8 13:23:56.874 [TX] - 04 03 30 07 28
2022/7/8 13:23:56.878 [RX] - 80 15 A5 A5 A5 A5 00 00 00 00 00 00 00 00 00 00 00 00 00 00 47 5C 08 00 00
    
```

Example2 : ISO/IEC 15693 Read UID and Read/Write Block Command in HEX.

//The ECHO command verifies the possibility of communication between a Host and the RYRR10S.

>>> 55

<<< 55

//Disable Rfider mode

>>> 09 04 68 01 07 10

<<< 00 00

//Enable Rfider mode

>>> 09 04 68 01 07 00

<<< 00 00

//Protocol Selection

>>> 02 02 01 05

<<< 00 00

//Modification of IndexMod & Gain in Analog Value register

>>> 09 04 68 01 01 50

<<< 00 00

//Inventory 1 Slot

>>> 04 03 26 01 00

<<< 80 0D 00 00 82 D6 74 A5 00 01 04 E0 65 CC 00

UID = 82 D6 74 A5 00 01 04 E0

//Read Multiple Block

>>> 04 04 02 23 00 01

04 = send receive command sent to the RYRR10S

04 = number of bytes to transmit

02 = request flag

23 = multiple read command code

00 = 1st block number

01 = number of blocks to read

<<< 80 0C 00 AA AA AA AA BB BB BB BB 9C CF 00

AA AA AA AA = 1st block data

BB BB BB BB = 2st block data

//Read Single Block

>>> 04 03 02 20 02

04 = send receive command sent to the RYRR10S

03 = length

02 = request flag

20 = single read command code

02 = 3st block number

<<< 80 08 00 09 10 11 12 5B 0C 00

09 10 11 12 = 3st block data

//Write Single Block

>>> 04 07 02 21 01 A5 A5 A5 A5

04 = send receive command sent to the RYRR10S

07 = length

02 = request flag

21 = single write command code

01 = 2st block number

A5 A5 A5 A5 = Data

<<< 87 00

```

2022/7/8 13:16:50.923 [TX] - 09 04 68 01 07 10
2022/7/8 13:16:50.925 [RX] - 00 00
2022/7/8 13:16:52.405 [TX] - 09 04 68 01 07 00
2022/7/8 13:16:52.407 [RX] - 00 00
2022/7/8 13:16:53.054 [TX] - 02 02 01 05
2022/7/8 13:16:53.056 [RX] - 00 00
2022/7/8 13:16:53.642 [TX] - 09 04 68 01 01 50
2022/7/8 13:16:53.645 [RX] - 00 00
2022/7/8 13:16:54.243 [TX] - 04 03 26 01 00
2022/7/8 13:16:54.251 [RX] - 80 0D 00 00 82 D6 74 A5 00 01 04 E0 65 CC 00
2022/7/8 13:16:55.570 [TX] - 04 04 02 23 00 0F
2022/7/8 13:16:55.595 [RX] - 80 44 00 A5 A5 A5 A5 A5 A5 09 10 11 12 13 14 15 16 17 18 19 20 21 22 23 24 25 26 27 28 29 30 31 32 33
34 35 36 37 38 39 40 11 22 33 44 00 00 00 00 00 00 00 00 00 00 00 00 00 00 00 00 00 00 00 00 00 00 BC EC 00
2022/7/8 13:16:56.218 [TX] - 04 03 02 20 02
2022/7/8 13:16:56.224 [RX] - 80 08 00 09 10 11 12 5B 0C 00
2022/7/8 13:16:57.313 [TX] - 04 07 02 21 01 A5 A5 A5 A5
2022/7/8 13:16:57.319 [RX] - 87 00
    
```

Sleep state command

00 07 0E 08 01 00 38 00 18 00 00 60 00 00 00 00 00

Hibernate state command

00 07 0E 08 04 00 04 00 18 00 00 00 00 00 00 00 00

***For more detail, please refer to the ST CR95HF information.**

ORDER INFORMATION

Ordering No.	Pin Header
RYRR10S	2 X 1.27mm pin header
RYRR10S_NP	Not mount