

RYB0801

2.4GHz Bluetooth 4.2 & 5.0
Low Energy Module
with Integrated Antenna

Datasheet

5



11*11*2.2mm



PRODUCT DESCRIPTION

The RYB080I is a Bluetooth v4.2 & v5.0 Low Energy Module.

By using the AT command which is developed by REYAX, your products could be fast and easily connected with the smartphones and all kinds of Bluetooth devices.

FEATURES

- Bluetooth v4.2 & v5.0 with Bluetooth Low Energy
- TI CC2640R2F ARM® Cortex®-M3 industry-standard chip
- Can connect two Bluetooth devices at the same time
- Support Host-Client role.
- Designed with embedded ceramic antenna, Suitable for SMD. Size: 115.94mm²
- Metal cover against EMI interference
- Transmitting, Receiving, Wake-up by only 2 UART pins
- Control easily by AT commands
- Standard Generic Attribute Profile (GATT)

APPLICATIONS

- Smart phone/Tablet accessories
- Remote monitoring and control
- Smart home
- Indoor positioning

APPROVED CERTIFICATIONS

- FCC CFR47 Part 15 (US)
- NCC (Taiwan)
- MIC (Japan)

SPECIFICATION

Item	Min.	Typical	Max.	Unit	Condition
Operation Voltage	1.8	3.0	3.8	V	VDD
RF Output Power	-21		5	dBm	
RF Sensitivity		-97		dBm	
Active Current		1.5		mA	UART function is available. BLE is broadcasting.
Advertising Average Current		0.2		mA	BLE broadcast once in 100ms.
Advertising Average Current		23		uA	BLE broadcast once in 1 second.
Advertising Average Current		6		uA	BLE broadcast once in 10 second.
Standby Current		3		uA	AT+CFUN=0
Wake Up Time		2		ms	
Simultaneous connections		2			
UART Baud Rate		9600	115200	bps	
RF Frequency Range	2400		2483.5	MHz	
Flash erase cycles		100		K	Cycles
Operating Temperature	-40	25	+85	°C	
Antenna					Embedded Ceramic Antenna
Weight		0.42		g	

PIN DESCRIPTION

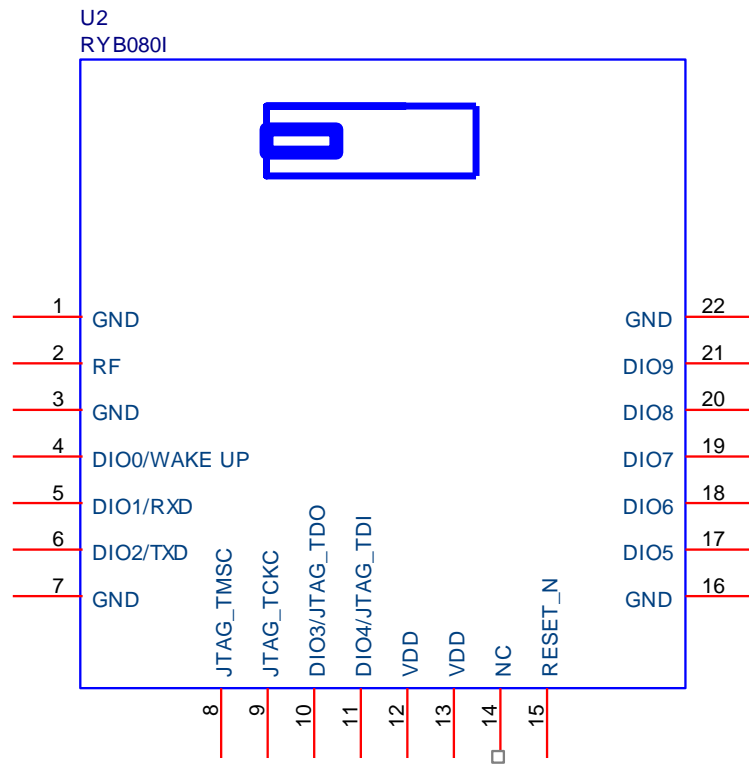

Pin	Name	I/O	Condition
1	GND	-	Ground
2	RF		External Antenna Version Used
3	GND	-	Ground
4	DIO0/WAKE UP	I	WAKE UP pin
5	DIO1/RXD	I	UART Data Input
6	DIO2/TXD	O	UART Data Output
7	GND	-	Ground
8	JTAG_TMSC	I/O	JTAG TMSC
9	JTAG_TCKC	I/O	JTAG TCKC
10	DIO3/JTAG_TDO	I/O	GPIO, High-drive capability, JTAG_TDO
11	DIO4/JTAG_TDI	I/O	GPIO, High-drive capability, JTAG_TDI
12	VDD	I	Power Supply
13	VDD	I	Power Supply
14	NC	-	Leave Unconnected.
15	RESET_N	I	Low Reset
16	GND	-	Ground
17	DIO5	I/O	GPIO, Sensor Controller, Analog
18	DIO6	I/O	GPIO, Sensor Controller, Analog
19	DIO7	I/O	GPIO, Sensor Controller, Analog
20	DIO8	I/O	GPIO, Sensor Controller, Analog
21	DIO9	I/O	GPIO, Sensor Controller, Analog
22	GND	-	Ground

APPLICATION SCHEMATIC

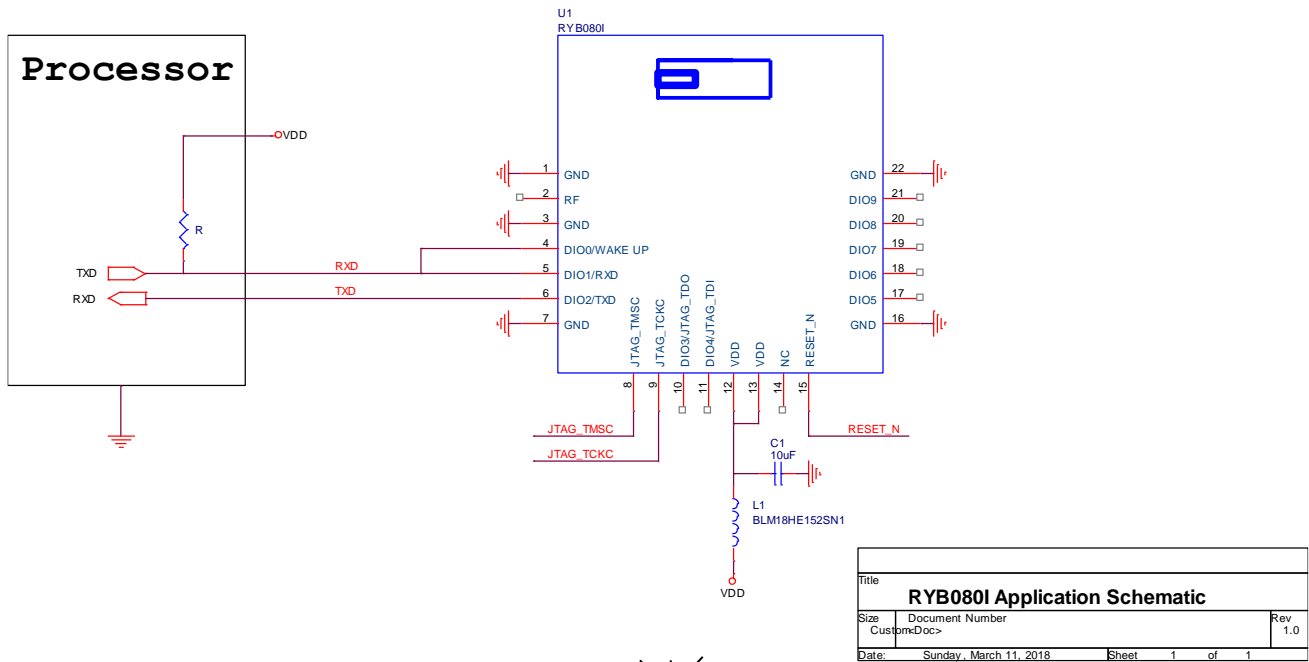

BLOCK DIAGRAM

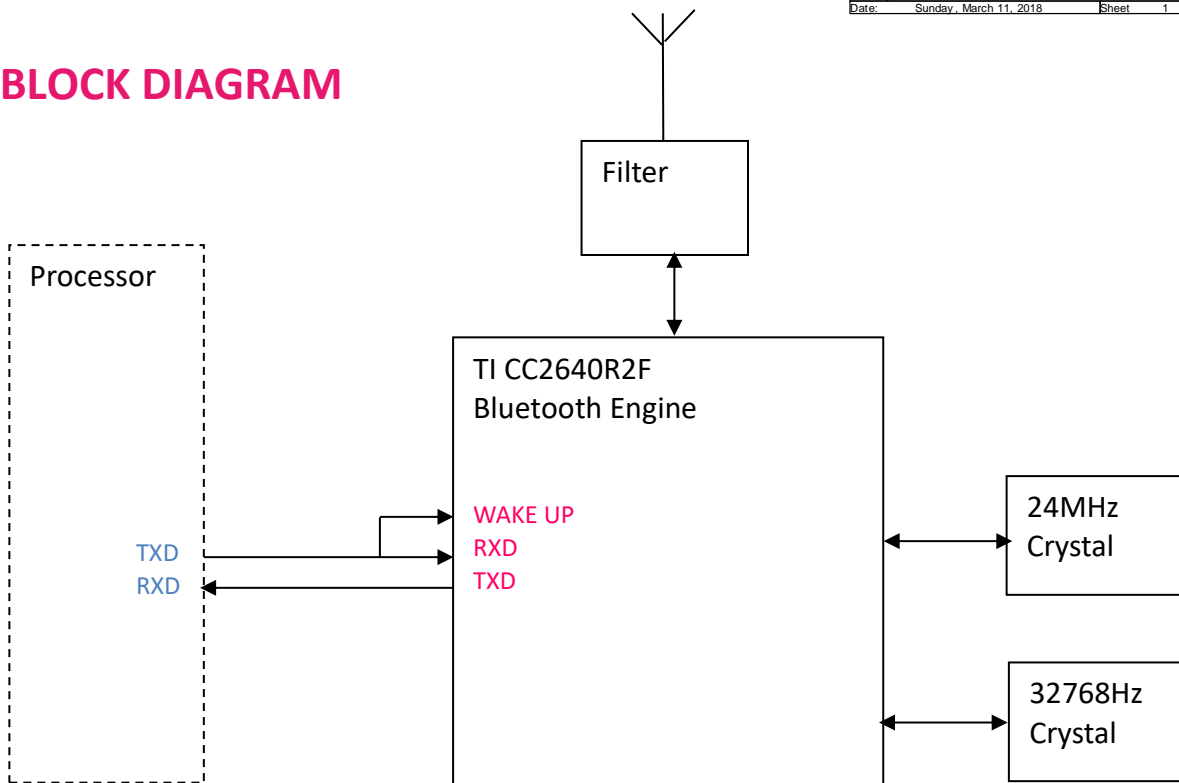

REFLOW SOLDERING

Consider the "IPC-7530 Guidelines for temperature profiling for mass soldering (reflow and wave) processes, published 2001. **Only single reflow soldering processes are recommended for REYAX modules. Repeated reflow soldering processes and soldering the module upside down are not recommended.**

Preheat phase

Initial heating of component leads and balls. Residual humidity will be dried out. Please note that this preheat phase will not replace prior baking procedures.

- Temperature rise rate: max. 3 °C/s If the temperature rise is too rapid in the preheat phase it may cause excessive slumping.
- Time: 60 - 120 s If the preheat is insufficient, rather large solder balls tend to be generated. Conversely, if performed excessively, fine balls and large balls will be generated in clusters.
- End Temperature: 150 - 200 °C If the temperature is too low, non-melting tends to be caused in areas containing large heat capacity.

Heating/ Reflow phase

The temperature rises above the liquidus temperature of 217°C. Avoid a sudden rise in temperature as the slump of the paste could become worse.

- Limit time above 217 °C liquidus temperature: 40 - 60 s
- Peak reflow temperature: 245 °C

Cooling phase

A controlled cooling avoids negative metallurgical effects (solder becomes more brittle) of the solder and possible mechanical tensions in the products. Controlled cooling helps to achieve bright solder fillets with a good shape and low contact angle.

- Temperature fall rate: max 4 °C/s To avoid falling off, the REYAX module should be placed on the topside of the motherboard during soldering.

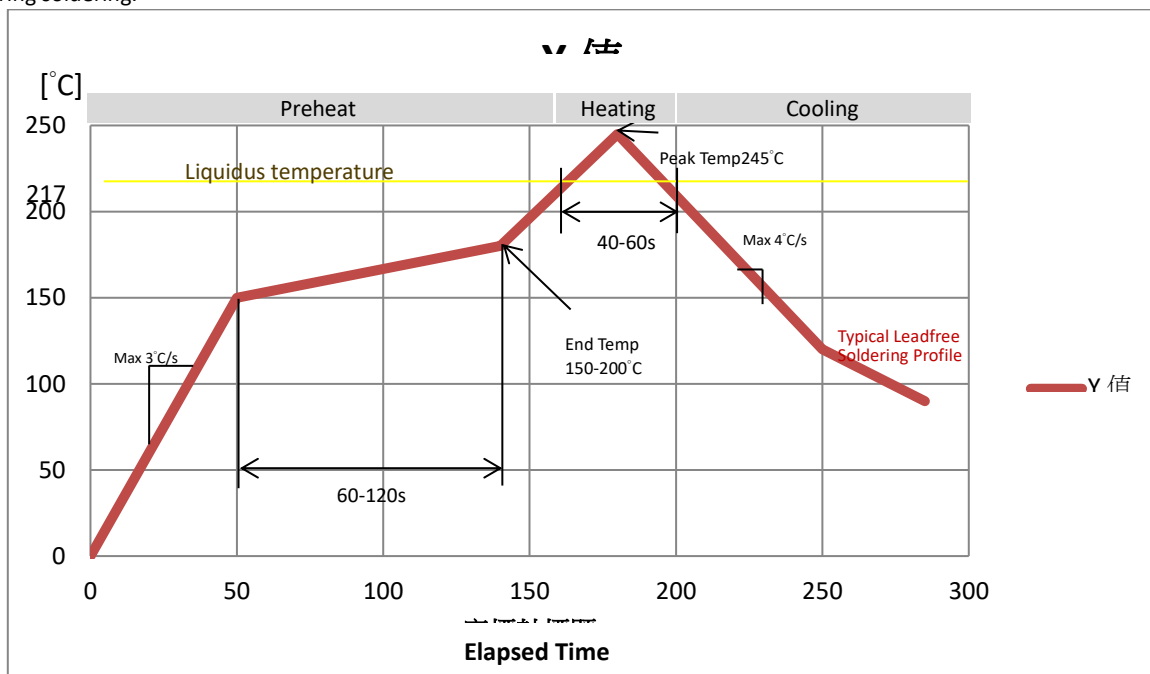

Recommended soldering profile

DIMENSIONS

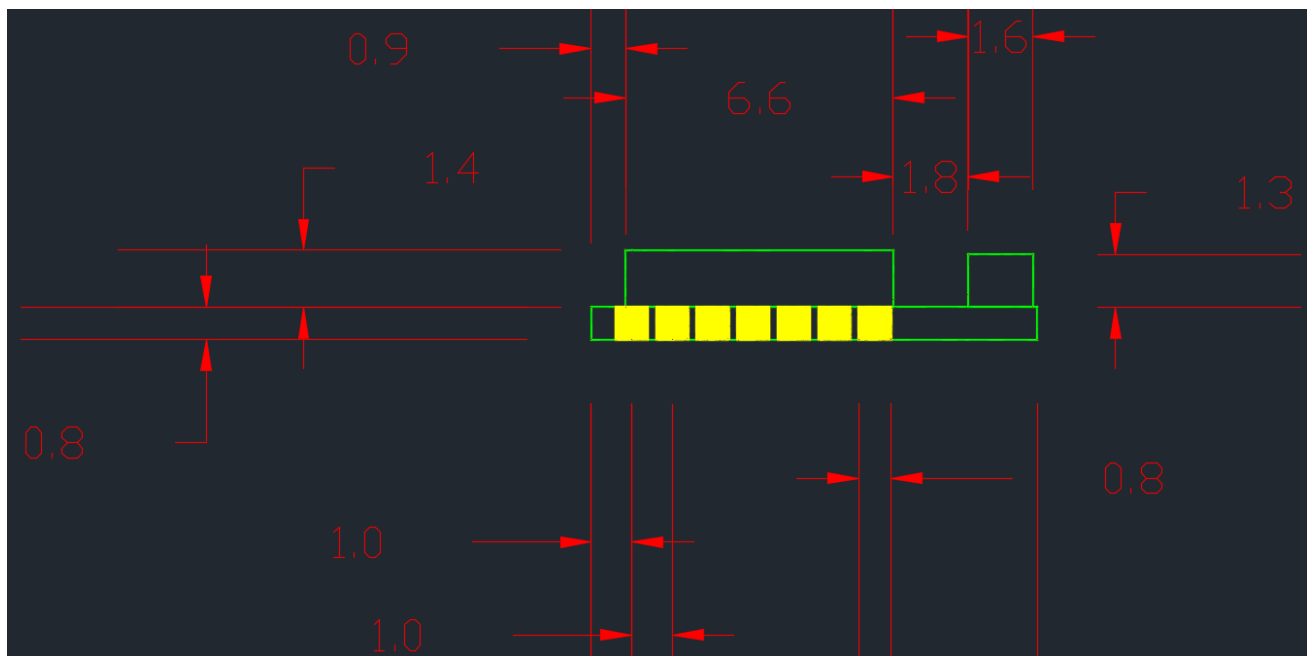
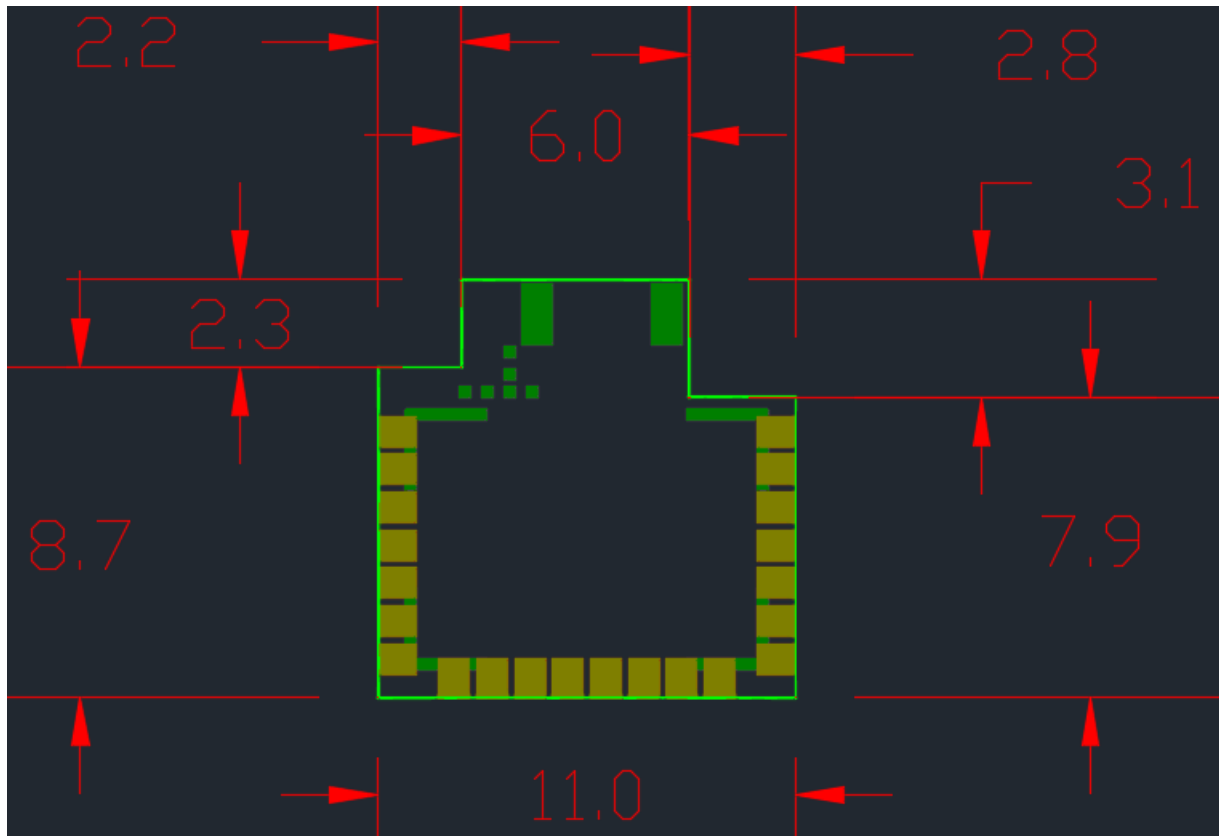

Unit : mm

LAYOUT FOOTPRINT RECOMMENDATIONS

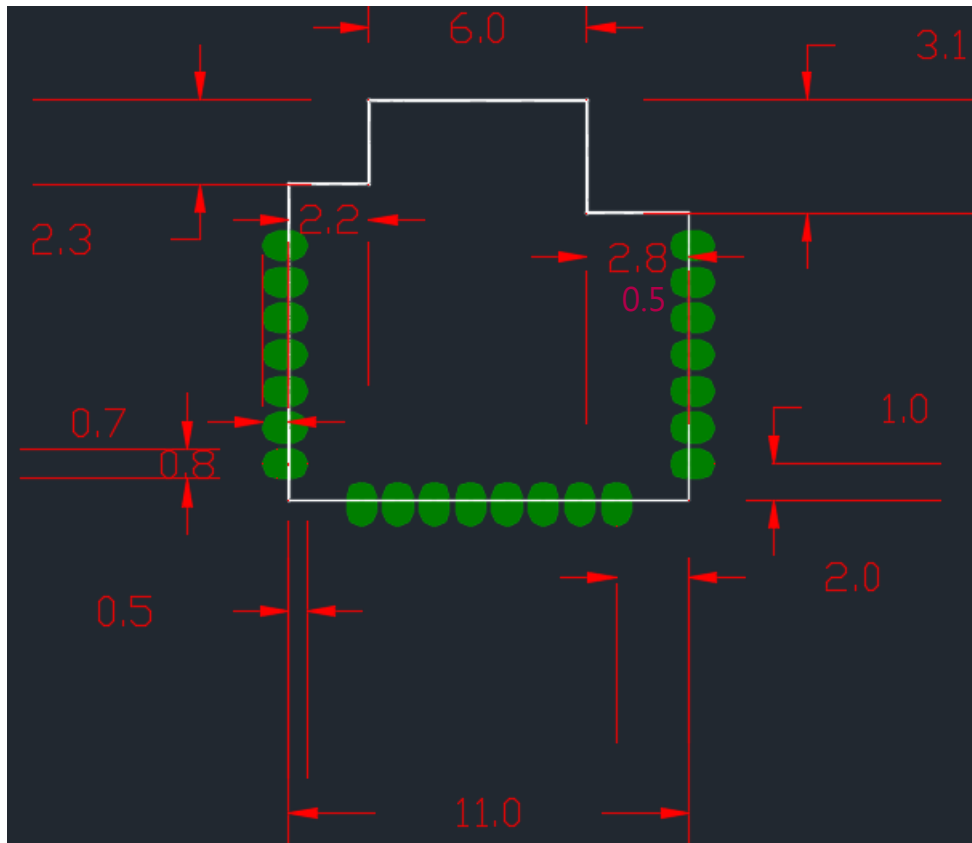

Unit : mm

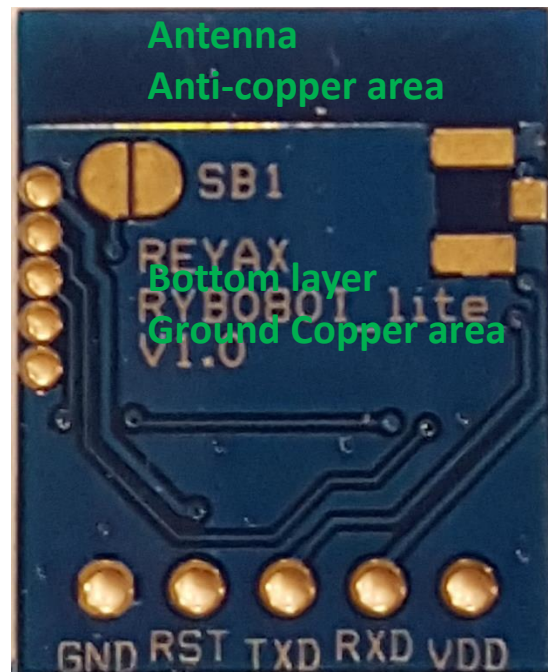
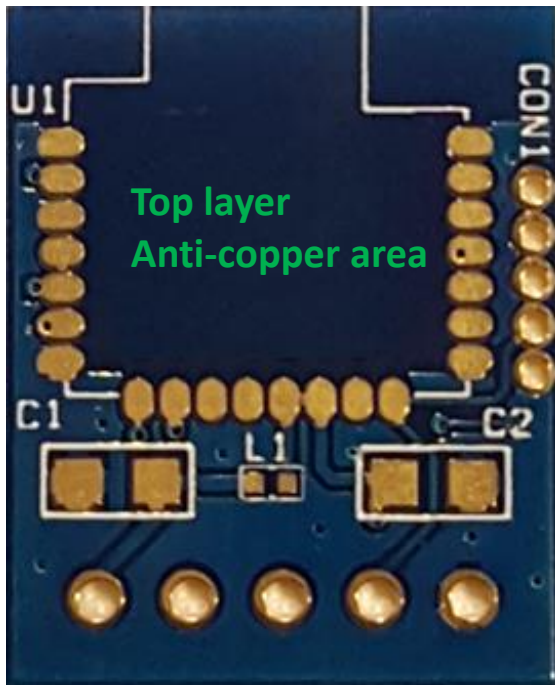

CERTIFICATIONS

- **MIC Japan compliance**



R 005-102444

上記のとおり、電波法第 38 条の 24 第 1 項の規定に基づく認証を行ったものであることを証する。

- **NCC Taiwan compliance**

低功率電波輻射性電機管理辦法:

第十二條 經型式認證合格之低功率射頻電機，非經許可，公司、商號或使用者均不得擅自變更頻率、加大功率或變更原設計之特性及功能。

第十四條 低功率射頻電機之使用不得影響飛航安全及干擾合法通信；經發現有干擾現象時，應立即停用，並改善至無干擾時方得繼續使用。前項合法通信，指依電信法規定作業之無線電通信。低功率射頻電機須忍受合法通信或工業、科學及醫療用電波輻射性電機設備之干擾。



CCAN19LP0100T4

- **FCC compliance**

Statement:

This device complies with part 15 of the FCC Rules. Operation is subject to the following two conditions:

- (1) This device may not cause harmful interference, and
- (2) this device must accept any interference received, including interference that may cause undesired operation.

NOTE: This equipment has been tested and found to comply with the limits for a Class B digital device, pursuant to part 15 of the FCC Rules. These limits are designed to provide reasonable protection against harmful interference in a residential installation. This equipment generates, uses and can radiate radio frequency energy and, if not installed and used in accordance with the instructions, may cause harmful interference to radio communications. However, there is no guarantee that interference will not occur in a particular installation.

If this equipment does cause harmful interference to radio or television reception, which can be determined by turning the equipment off and on, the user is encouraged to try to correct the interference by one or more of the following measures:

- Reorient or relocate the receiving antenna.
- Increase the separation between the equipment and receiver.
- Connect the equipment into an outlet on a circuit different from that to which the receiver is connected.
- Consult the dealer or an experienced radio/TV technician for help.

Changes or modifications not expressly approved by the party responsible for compliance could void the user's authority to operate the equipment.

LABEL OF THE END PRODUCT:

The final end product must be labeled in a visible area with the following " Contains TX FCC ID : QLY-RYB080I ". If the size of the end product is larger than 8x10cm, then the following FCC part 15.19 statement has to also be available on the label: This device complies with Part 15 of FCC rules. Operation is subject to the following two conditions: (1) this device may not cause harmful interference and (2) this device must accept any interference received, including interference that may cause undesired operation.



QLY-RYB080I

AT COMMAND

[1] After booting up, the RYB080I is in the low-energy broadcasting mode. While the pin4(WAKE UP) was triggered by any entered signals (Example: Sending a character “A”), UART interface will be woken. The RYB080I can receive AT Command at this status. When UART interface does not receive any commands in 5 seconds, it will again, turn into the low energy broadcasting mode. This mode can be modified by using AT command.

[2] It is required to key in “**enter**” or “**\r\n**” (0x0D 0x0A) in the end of all AT Commands. Add “**?**” in the end of the commands to ask the current setting value.

[3] RYB080I have two Bluetooth protocol port, can separately be the role of HOST or CLIENT.

[4] AT Command can input from RXD and the result outputs by TXD.

[5] AT Command can also input by wireless after Bluetooth connection, and the result outputs by TXD.

1. AT to test if the module responds

Syntax	Response
AT	+OK

2. Software RESET

Syntax	Response
AT+RESET	+READY

3. AT+NAME to set the broadcast name

Syntax	Response
AT+NAME=<Name> <name> at most 20 ASCII characters Example: Set the broadcast name as “REYAX_BLE_RYB080I” AT+NAME=REYAX_BLE_RYB080I * It will work after RESET. * It will be memorized in Flash after setting.	+OK
AT+NAME?	+NAME= REYAX_BLE_RYB080I

4. AT+ATTR to set the device name

Syntax	Response
<p>AT+ATTR= <attribute> <attribute> at most 20 ASCII characters</p> <p>Example: Set the device name as "REYAX_BLE_RYB080I"</p> <p>AT+ATTR= REYAX_BLE_RYB080I</p> <p>* It will work after sending AT+RESET or pressing RESET bottom. * Some iOS APP use this name to recognize the Bluetooth device. * It will be memorized in Flash after setting.</p>	+OK
AT+ATTR?	+ATTR= REYAX_BLE_RYB080I

5. AT+CRFOP to set the RF broadcasting output power

Syntax	Response
<p>AT+CRFOP= <Power> <Power>range 0 to C</p> <p>0=-21dBm 1=-18dBm 2=-15dBm 3=-12dBm 4=-9dBm 5=-6dBm 6=-3dBm 7=0dBm 8=1dBm 9=2dBm A=3dBm B=4dBm C=5dBm(default)</p> <p>Example : set the output power as -9dBm AT+CRFOP=4</p> <p>* It will be memorized in Flash after setting.</p>	+OK
AT+CRFOP?	+CRFOP=4

6. **AT+CNE** to set the BLE can be connected or not

Syntax	Response
<p>AT+CNE= <Connect></p> <p><Connect> set the BLE can be connected or not 0 : Reject other Bluetooth devices connecting. 1 : Accept other Bluetooth devices connecting (default)</p> <p>Example: Reject other Bluetooth devices connecting AT+CNE=0</p> <p>* It will be memorized in Flash after setting and RESET.</p>	+RESET!
AT+CNE?	+CNE=0

7. **AT+PERIOD** Setting the BLE broadcasting period

Syntax	Response
<p>AT+PERIOD = <Parameter></p> <p><Parameter> > range 0 to 9 0:25ms 1:50ms 2:100ms (default) 3:200ms 4:500ms 5:1s 6:2s 7:3s 8:5s 9:10s</p> <p>Example : Setting the BLE broadcasting period is 500ms in 1second. AT+PERIOD=4</p> <p>* It will work after RESET. * It will be memorized in Flash after setting.</p>	+OK
AT+PERIOD?	+PERIOD=4

8. **AT+PWMODE** to set the saving power mode

Syntax	Response
<p>AT+PWMODE=<Mode> <mode> is the power saving mode</p> <p>0 : Fully Function Mode: UART and BLE broadcasting is in operation.</p> <p>1 : Standard Saving Power Mode: After pin4 was triggered, UART can send the AT Command. If pin4 was not triggered again in 5 seconds, it will turn into only broadcasting mode. (default)</p> <p>2 : Sleep Mode: Under the Standard Saving Power Mode turning off the BLE broadcasting function.</p> <p>3 : Customized Saving Power Mode: Customized the setting of the turn-on and turn-off cycle time of Bluetooth broadcasting.</p> <p>AT+PWMODE=3, <Seconds of BLE Broadcasting turned-on>, < Seconds of BLE Broadcasting turned-off>, The range of turned-on and turned-off seconds is <000~600></p> <p>*Noticed: The time of<Seconds of BLE Broadcasting turned-on> have to be longer or equal to the BLE broadcasting period.</p> <p>Example: Setting the third power mode, the cycle of, turned-on for 1 sec, turned-off for 20 seconds.</p> <p>AT+PWMODE=3,001,020</p>	<p>+OK</p>
<p>AT+PWMODE?</p>	<p>+ PWMODE=3</p>

9. AT+CFUN to set the BLE broadcast (Advertising) ON/OFF

Syntax	Response
<p>AT+CFUN=<Advertising></p> <p><Advertising> is the switch of BLE broadcast</p> <p>0 : BLE broadcast off</p> <p>1 : BLE broadcast on (default)</p> <p>Example: Setting the BLE broadcast off.</p> <p>AT+CFUN=0</p>	+OK
AT+CFUN?	+CFUN=0

10. AT+IPR to set the UART baud rate

Syntax	Response
<p>AT+IPR=<Rate></p> <p><Rate> is the UART Baud Rate</p> <p>4 : 9600 (default)</p> <p>5 : 19200</p> <p>6 : 38400</p> <p>7 : 57600</p> <p>8 : 115200</p> <p>Example: Set the baud rate as 57600, it will memorize the setting and reset the module.</p> <p>AT+IPR=7</p> <p>* It will work after RESET.</p> <p>* It will be memorized in Flash after setting.</p>	+OK
AT+IPR?	+IPR=7

*Byte Size=8 · Parity=None · Stop Bits=1

11. AT+ADDR to inquire MAC address

Syntax	Response
AT+ADDR?	+ADDR=123456ABCDEF

12. **AT+ENTER** to set if needed to key in ENTER (0x0D 0x0A) in the end of the commands

Syntax	Response
<p>AT+ENTER= <Status></p> <p><state> is whether needed to key in ENTER (0x0D 0x0A) in the end of the commands.</p> <p>0 : no need</p> <p>1 : needed (default)</p> <p>Example: setting there is no need to key in ENTER (0x0D 0x0A) in the end of the commands.</p> <p>AT+ENTER=0</p> <p>* It will be memorized in Flash after setting.</p>	+OK
AT+ENTER?	+ENTER=0

13. **AT+CONNECT?** to inquire the connection status

Syntax	Response
AT+CONNECT?	<p>+CONNECT= <Port1>, <Port2></p> <p><Port1>, <Port2> are the status of two BLE protocol port</p> <p>0: Unconnected</p> <p>H: Connecting, represent "Host"</p> <p>C: Connecting, represent "Client"</p>
AT+CONNECT?	+CONNECT=0, C

14. AT+SCAN to scan the Peripherals near by the Central

Syntax	Response
<p>AT+SCAN</p> <p>Example: Scan the Peripherals nearby which can be connected.</p>	<p>+.....</p> <p>+<NO.>,0x<MAC>, <rssi></p> <p>+<NO.>,0x<MAC>, <rssi></p> <p>+<NO.>,0x<MAC>, <rssi></p> <p>+<NO.>,0x<MAC>, <rssi></p> <p>+<NO.>,0x<MAC>, <rssi></p> <p>+Found <Quantity></p> <p><NO.> item number of Peripherals: 1~5</p> <p><MAC> MAC address</p> <p><rssi> output power of Peripherals: - xxdBm <Quantity> quantity of found Peripherals; the maximum is 5.</p> <p>+.....</p> <p>+1:0x341513E481FA, BLE_MODULE , - 46dBm</p> <p>+2:0x546C0E591BD2, BLE5_MODULE, - 31dBm</p> <p>+Found 2</p>

15. AT+CON the Central connect to a Peripheral by MAC address

Syntax	Response
<p>AT+CON=<MAC></p> <p><MAC> MAC address</p> <p>Example: The Central connect to the Peripheral whose MAC address is 123456ABCDEF</p> <p>AT+CON=123456ABCDEF</p>	<p>++++<Role><Port></p> <p><Role> "H" represent "Host" ; "C" represent "Client"</p> <p><Port>is the BLE protocol port</p> <p>++++H1</p>

* Suitable for Reyax BLE products

16. **AT+CONT** The Central connect to a Peripheral by the item number from AT+SCAN

Syntax	Response
<p>AT+CONT=<NO.></p> <p><NO.> the item number of the Peripherals: 1~8</p> <p>Example: The Central connect to the Peripheral whose item number is 2 from AT+SCAN.</p> <p>AT+CONT=2</p>	<p>++++<Role><Port></p> <p><Role> "H" represent "Host" ; "C" represent "Client"</p> <p><Port>is the BLE protocol port</p> <p>++++H2</p>

* Suitable for Reyax BLE products

17. **AT+DCON** initiative disconnected

Syntax	Response
<p>AT+DCON=<Port></p> <p><Port>is the BLE protocol port</p> <p>0: disconnect Port1 & Port2 1: disconnect Port1 2: disconnect Port2</p> <p>Example: BLE protocol port 1 disconnected</p> <p>AT+DCON=1</p>	<p>+-----<Role><Port></p> <p><Role> "H" represent "Host" ; "C" represent "Client"</p> <p><Port>is the BLE protocol port</p> <p>+-----H1</p>

18. **AT+GPIO** to control the GPIO output is High or Low

Syntax	Response
<p>AT+GPIO=<GPIO NO.>, <H/L></p> <p>< GPIO NO. >rang is 5/6/7</p> <p><H/L> GPIO output voltage is 0 represent Low, 1 represent High</p> <p>Example: Setting the output of GPIO port 5 is High.</p> <p>AT+GPIO=5,1</p>	<p>+OK</p>

19. Connecting received data and Receiving send data

Data Format	Response
<p>[1] When connected with BLE device it will show,</p> <p>++++<Role><Port> +MTU:<Data></p> <p><Role> "H" represent "Host" ; "C" represent "Client"</p> <p><Port> the serial number of protocol port is 1 or 2 <Data> the MAX data Byte of a single packet</p> <p>Example: Protocol 1 built the connection, the role is Client, the data can be delivered by a single packet is 62Bytes (MTU-3)</p>	<p>++++C1 +MTU:65</p>
<p>[2] Receiving data format :<RxData> <RxData> <RxData> is the received data</p> <p>Example: When received the characters FGHIJ through the UUID FFF1 from the remote.</p>	<p>FGHIJ</p>
<p>[3] Receiving data format 2 (using UUID FFF4) <Port>:< RxData > < Port>: the number of BLE protocol port <RxData>: received data</p> <p>Example: As receiving the character string "FGHIJ" via protocol port 1 through UUID FFF4 from the Client</p>	<p>1: FGHIJ</p>
<p>[4] Sending data <TxData> <TxData>: the data going to be sent</p> <p>Example: Sending "ABCDE" to BLE protocol port 1 & 2 through UUID FFF4 ABCDE</p>	<p>+1:OK +2:OK</p>

<p>[5] Specified port sending data (Specified BLE protocol port send data)</p> <p><Port> <TxData></p> <p><Port>: the number of BLE protocol port</p> <p><TxData>: the data going to be sent</p> <p>Example: Sending "ABCDE" to BLE protocol port 2 through UUID FFF4</p> <p>2>ABCDE</p> <p>Under this mode, the amount of TxData can't be over with MTU size -5.</p> <p>Example: If the MTU is 62 Bytes then the biggest amount of TxData is 60. (If including "enter" , "enter" contains 2 Bytes)</p>	<p>+2:OK</p>
---	--------------

20. AT+CGMS? reading information of software versions

Syntax	Response
AT+CGMS?	+CGMS=RYB080I_56312E30

21. Other response messages

Syntax	Response
After RESET	+READY +ENTER=1

** Our Company is not responsible for any technical malfunction or other problems if users modify the module by themselves.*

TOOLS

Download Access Port which is a serial port monitoring tool for Windows. <http://www.sudt.com/en/ap/>

ORDER INFORMATION

Ordering No.	Antenna
RYB080I	Internal
RYB080E	External

* If you need the transparent mode, please contact us.