



140x140x25mm

- Airflow: 62.1~115.3 CFM
- Static Pressure: 1.3~4.0mm-H₂O
- Blade / Housing: Plastic Material UL 94V-0 P.B.T.
- Lead Wire: UL1061 #24 AWG
- Weight: 182g

Model No.	Bearing	Rated Voltage VDC	Operating Voltage Range VDC	Speed RPM	Max. Airflow CFM	Max. Static Pressure mm-H ₂ O	Current mA	Power Consumption W	Life at 40°C L10 Hour	P-Q Curve	Noise Level dB(A)
FD121425LL-N	L	12	7~13.2	1050	62.1	1.3	70	0.84	50000	3	21.7
FD121425ML-N	L			1450	87.1	2.5	170	2.04	50000	2	31.6
FD121425HL-N	L			1850	115.3	4.0	370	4.44	50000	1	40.6
FD121425LB-N	2B			1050	62.1	1.3	70	0.84	80000	3	21.7
FD121425MB-N	2B			1450	87.1	2.5	170	2.04	80000	2	31.6
FD121425HB-N	2B			1850	115.3	4.0	370	4.44	75000	1	40.6

2B: 2-ball bearing L: sintetico bearing S: sleeve bearing

Voltage Available

05 12 24 48

Bearing System Available

2B L S

Function Available

N A I F R Q S T M V C P D W U

PERFORMANCE P-Q CURVE

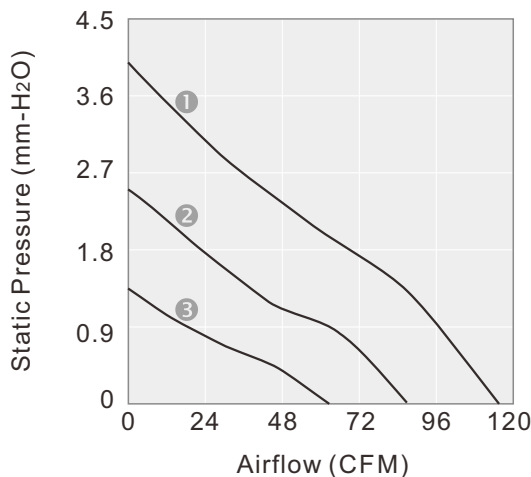

OUTLINE DIMENSIONS

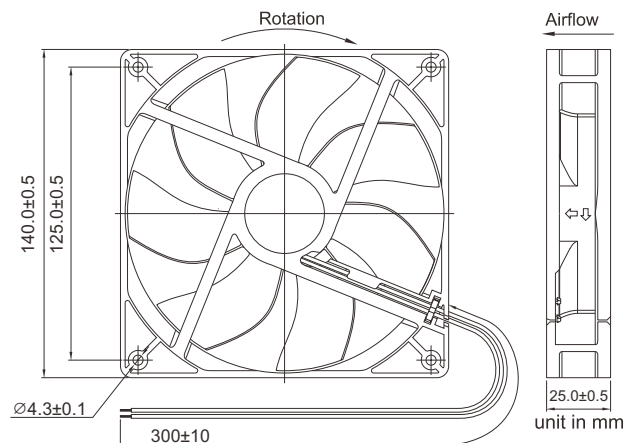

Please refer to *Model Numbering System* for bearing, function and speed level indication. Specifications are subject to changes without notice. Please refer to the formally issued product specification via contacting Y.S. TECH sales department. Visit Y.S. TECH web site at <http://www.ystech.com.tw> for updated information. Customized Specifications are designed accordingly