

# Heat Sink & Thermal Model

We are professional in:

- 「High Precision Machinery」
- 「Multi-Assembly & Flexibility Manufacture」
- 「Surface Coating & Coloring」

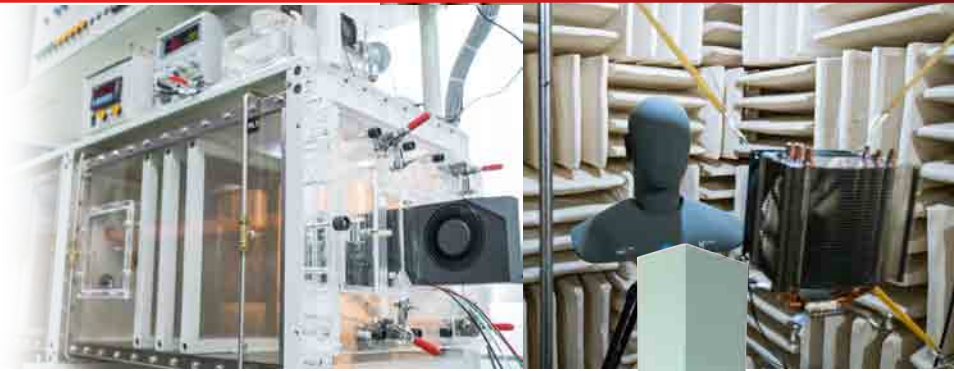

## Technical Support

1. System-Based Thermal & Flow Analysis Simulation.
2. Thermal Resistant & Flow Testing
3. Acoustic Analysis & Testing
4. CMM Measurement & Analysis
5. Precision Machining(Tolerance Range : IT6~IT8)
6. Soldering Technology
7. Thermal Components Integration & Assembly
8. Coating, Plating & Anodizing



## Product Application

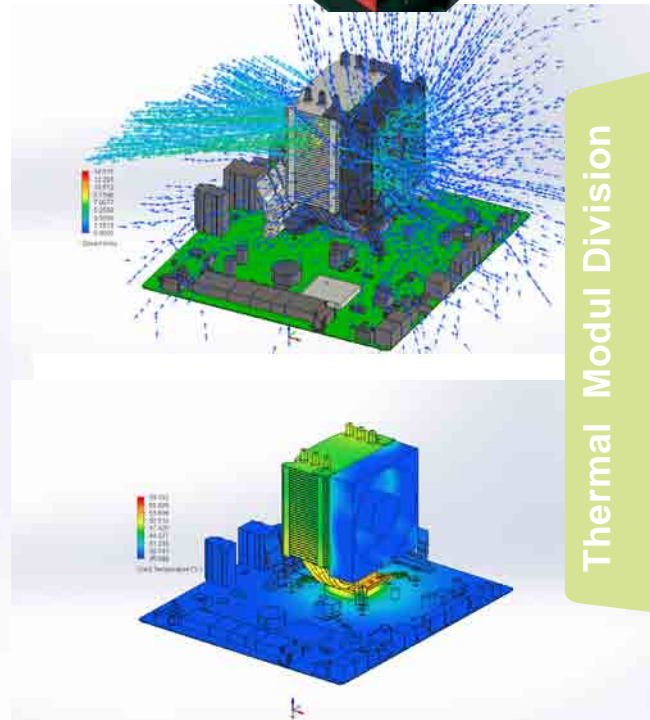

# Process and Material



Aluminum Extrusion  
AL 6063 、 AL 6061



Die-Casting  
ADC12 、 ADC10 、 A380



Punching  
AL 1050 、 AL 1100  
CU 1100



Soldering  
Copper - Copper,  
Copper - Aluminum,  
Aluminum - Aluminum



Skiving  
AL 6063  
CU 1100



CNC  
AL 6063 、 AL 6061 、 ADC10 、 ADC12 、 A380  
CU 1100

# Surface Finishing



Mechanical surface finishing  
Sand blasting



Hairline finishing

Chemical surface finishing  
Aluminum Anodizing



Electro-less Nickel Plating



Anti-oxidation



Chromate

## High Precision Machinery

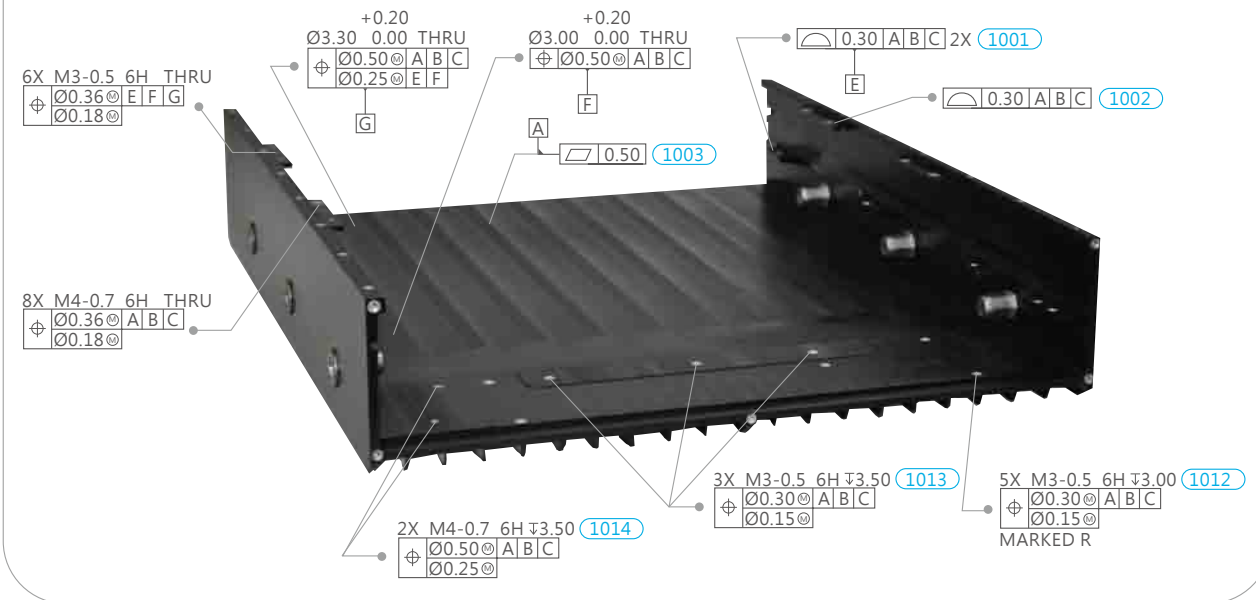

The thermal modules and heatsink series are all customized design and manufacture. Please write down your specification and demand by the email address: [ystech@ystech.com.tw](mailto:ystech@ystech.com.tw) or visit Y.S. Tech website, leave your information to us. We will contact with you as soon.

