

3000 WATT TVS COMPONENT



DO-214AB PACKAGE

APPLICATIONS

- Power Supply
- AC/DC Applications
- Telecom

FEATURES

- UL Registered
- IEC Compatibility 61000-4-2 (ESD)
- IEC Compatibility 61000-4-4 (EFT)
- IEC Compatibility 61000-4-5 (Surge)
- Glass Passivated Chip
- 3000 Watts Peak Pulse Power per Line ($t_p = 10/1000\mu s$)
- Low Leakage Current
- Unidirectional and Bidirectional Configurations
- Excellent Clamping Capability
- Very Fast Response Time
- Available in Multiple Voltages
- RoHS Compliant
- REACH Compliant

MECHANICAL CHARACTERISTICS

- Molded JEDEC DO-214AB Package
- Approximate Weight: 0.248 grams
- Lead-Free Pure-Tin Plating (Annealed)
- Solder Reflow Temperature:
Pure-Tin - Sn, 100: 260-270°C
- 16mm Tape and Reel Per EIA Standard 481
- Terminal: Solderable per MIL-STD-750, Method 2026
- Flammability Rating UL 94V-0

PIN CONFIGURATIONS

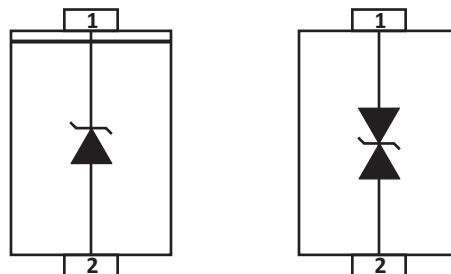

TYPICAL DEVICE CHARACTERISTICS

MAXIMUM RATINGS @ 25°C Unless Otherwise Specified

PARAMETER	SYMBOL	VALUE	UNITS
Operating Temperature	T_A	-55 to 150	°C
Storage Temperature	T_{STG}	-55 to 150	°C
Peak Pulse Power (tp = 10/1000µs) - See Figure 1 and Note 2	P_{PP}	3000	Watts
Power Dissipation on Infinite Heatsink at $T_L = 75^\circ\text{C}$	P_D	6.0	Watts
Peak Forward Surge Current, 8.3ms single half sinewave - Unidirectional Only (Note 2)	I_{FSM}	300	Amps
Maximum Instantaneous Forward Voltage at 100A - Unidirectional Only	V_F	3.5	V

NOTE

1. Non-repetitive current pulse per Figure 2 and derated above $T_A = 25^\circ\text{C}$ per Figure 2.
2. Measured on 8.3ms single half sinewave or equivalent square wave, duty cycle = 4 pulses per minute maximum.

ELECTRICAL CHARACTERISTICS PER LINE @ 25°C Unless Otherwise Specified

PART NUMBER (Notes 1-3)	DEVICE MARKING		REVERSE STAND-OFF VOLTAGE V_{RWM} VOLTS	BREAKDOWN VOLTAGE $V_{(BR)} @ I_T$ VOLTS		TEST CURRENT $@ I_T$ mA	MAXIMUM CLAMPING VOLTAGE (Fig. 2) $@ I_P$ V_C VOLTS	MAXIMUM REVERSE SURGE CURRENT $@ I_{PP}$ AMPS	MAXIMUM REVERSE LEAKAGE CURRENT $@ V_{RWM}$ I_R µA
	UNI	BI		MIN	MAX				
SMDJ5.0	RDD	DDD	5.0	6.40	7.30	50	9.6	313	5000
SMDJ5.0A	RDE	DDE	5.0	6.40	7.00	50	9.2	326	5000
SMDJ6.0	RDF	DDF	6.0	6.67	8.15	50	11.4	263	5000
SMDJ6.0A	RDG	DDG	6.0	6.67	7.37	50	10.3	291	5000
SMDJ6.5	RDH	DDH	6.5	7.22	8.82	50	12.3	244	2000
SMDJ6.5A	RDK	DDK	6.5	7.22	7.98	50	11.2	268	2000
SMDJ7.0	RDL	DDL	7.0	7.78	9.51	50	13.3	226	1000
SMDJ7.0A	PDM	DDM	7.0	7.78	8.60	50	12.0	250	1000
SMDJ7.5	PDN	DDN	7.5	8.33	10.20	5	14.3	210	250
SMDJ7.5A	PDP	DDP	7.5	8.33	9.21	5	12.9	233	250
SMDJ8.0	PDQ	DDQ	8.0	8.89	10.90	5	15.0	200	150
SMDJ8.0A	PDR	DDR	8.0	8.89	9.83	5	13.6	221	150
SMDJ8.5	PDS	DDS	8.5	9.44	11.50	5	15.9	189	50
SMDJ8.5A	PDT	DDT	8.5	9.44	10.40	5	14.4	208	50
SMDJ9.0	PDU	DDU	9.0	10.00	12.20	5	16.9	178	20
SMDJ9.0A	PDV	DDV	9.0	10.00	11.10	5	15.4	195	20
SMDJ10	PDW	DDW	10.0	11.10	13.60	5	18.8	160	15
SMDJ10A	PDX	DDX	10.0	11.10	12.30	5	17.0	176	15
SMDJ11	PDY	DDY	11.0	12.20	14.90	5	20.1	149	2
SMDJ11A	PDZ	DDZ	11.0	12.20	13.50	5	18.2	165	2
SMDJ12	PED	DED	12.0	13.30	16.30	5	22.0	136	2
SMDJ12A	PEE	DEE	12.0	13.30	14.70	5	19.9	151	2

TYPICAL DEVICE CHARACTERISTICS

ELECTRICAL CHARACTERISTICS PER LINE @ 25°C Unless Otherwise Specified

PART NUMBER (Notes 1-3)	DEVICE MARKING		REVERSE STAND-OFF VOLTAGE V_{RWM} VOLTS	BREAKDOWN VOLTAGE $V_{(BR)} @ I_T$ VOLTS		TEST CURRENT @ I_T mA	MAXIMUM CLAMPING VOLTAGE (Fig. 2) @ I_p V_c VOLTS	MAXIMUM REVERSE SURGE CURRENT @ I_{PP} AMPS	MAXIMUM REVERSE LEAKAGE CURRENT @ V_{RWM} I_R μA
	UNI	BI		MIN	MAX				
	SMDJ13	PEF	DEF	13.0	14.40	17.60	5	23.8	126
SMDJ13A	PEG	DEG	13.0	14.40	15.90	5	21.5	140	2
SMDJ14	PEH	DEH	14.0	15.60	19.10	5	25.8	116	2
SMDJ14A	PEK	DEK	14.0	15.60	17.20	5	23.2	129	2
SMDJ15	PEL	DEL	15.0	16.70	20.40	5	26.9	112	2
SMDJ15A	PEM	DEM	15.0	16.70	18.50	5	24.4	123	2
SMDJ16	PEN	DEN	16.0	17.80	21.80	5	28.8	104	2
SMDJ16A	PEP	DEP	16.0	17.80	19.70	5	26.0	115	2
SMDJ17	PEQ	DEQ	17.0	18.90	23.10	5	30.5	98.4	2
SMDJ17A	PER	DER	17.0	18.90	20.90	5	27.6	109	2
SMDJ18	PES	DES	18.0	20.00	24.40	5	32.2	93.2	2
SMDJ18A	PET	DET	18.0	20.00	22.10	5	29.2	103	2
SMDJ19	PEA	DEA	19.0	21.13	25.76	5	34.0	88.2	2
SMDJ19A	PEB	DEB	19.0	21.10	23.30	5	30.8	97.5	2
SMDJ20	PEU	DEU	20.0	22.20	27.10	5	35.8	83.8	2
SMDJ20A	PEV	DEV	20.0	22.20	24.50	5	32.4	92.6	2
SMDJ22	PEW	DEW	22.0	24.40	29.80	5	39.4	76.4	2
SMDJ22A	PEX	DEX	22.0	24.40	26.90	5	35.5	84.5	2
SMDJ24	PEY	DEY	24.0	26.70	32.60	5	43.0	69.8	2
SMDJ24A	PEZ	DEZ	24.0	26.70	29.50	5	38.9	77.1	2
SMDJ26	PFD	DFD	26.0	28.90	35.30	5	46.6	64.4	2
SMDJ26A	PFE	DFE	26.0	28.90	31.90	5	42.1	71.3	2
SMDJ28	PFF	DFF	28.0	31.10	38.00	5	50.0	60.0	2
SMDJ28A	PFG	DFG	28.0	31.10	34.40	5	45.4	66.1	2
SMDJ30	PFH	DFH	30.0	33.30	40.70	5	53.5	56.1	2
SMDJ30A	PFK	DFK	30.0	33.30	36.80	5	48.4	62.0	2
SMDJ33	PFL	DFL	33.0	36.70	44.90	5	59.0	50.9	2
SMDJ33A	PFM	DFM	33.0	36.70	40.60	5	53.3	56.3	2
SMDJ36	PFN	DFN	36.0	40.00	48.90	5	64.3	46.7	2
SMDJ36A	PFP	DFP	36.0	40.00	44.20	5	58.1	51.6	2
SMDJ40	PFQ	DFQ	40.0	44.40	54.30	5	71.4	42.0	2
SMDJ40A	PFR	DFR	40.0	44.40	49.10	5	64.5	46.5	2
SMDJ43	PFS	DFS	43.0	47.80	58.40	5	76.7	39.1	2
SMDJ43A	PFT	DFT	43.0	47.80	52.80	5	69.4	43.2	2

TYPICAL DEVICE CHARACTERISTICS

ELECTRICAL CHARACTERISTICS PER LINE @ 25°C Unless Otherwise Specified

PART NUMBER (Notes 1-3)	DEVICE MARKING		REVERSE STAND-OFF VOLTAGE V_{RWM} VOLTS	BREAKDOWN VOLTAGE $V_{(BR)} @ I_T$ VOLTS		TEST CURRENT @ I_T mA	MAXIMUM CLAMPING VOLTAGE (Fig. 2) @ I_p V_c VOLTS	MAXIMUM REVERSE SURGE CURRENT @ I_{PP} AMPS	MAXIMUM REVERSE LEAKAGE CURRENT @ V_{RWM} I_R μA
	UNI	BI		MIN	MAX				
	SMDJ45	PFU	DFU	45.0	50.0	61.10	5	80.3	37.4
SMDJ45A	PFV	DFV	45.0	50.0	55.30	5	72.7	41.3	2
SMDJ48	PFW	DFW	48.0	53.30	65.10	5	85.5	35.1	2
SMDJ48A	PFX	DFX	48.0	53.30	58.90	5	77.4	38.8	2
SMDJ51	PFY	DFY	51.0	56.70	69.30	5	91.1	32.9	2
SMDJ51A	PFZ	DFZ	51.0	56.70	62.70	5	82.4	36.4	2
SMDJ54	RGD	DGD	54.0	60.00	73.30	5	96.3	31.2	2
SMDJ54A	RGE	DGE	54.0	60.00	66.30	5	87.1	34.4	2
SMDJ58	RGF	DGF	58.0	64.40	78.70	5	103.0	29.1	2
SMDJ58A	RGG	DGG	58.0	64.40	71.20	5	93.6	32.1	2
SMDJ60	RGH	DGH	60.0	66.70	81.50	5	107.0	28.0	2
SMDJ60A	PGK	DGK	60.0	66.70	73.70	5	96.8	31.0	2
SMDJ64	PGL	DGL	64.0	71.10	86.90	5	114.0	26.3	2
SMDJ64A	PGM	DGM	64.0	71.10	78.60	5	103.0	29.1	2
SMDJ70	PGN	DGN	70.0	77.80	95.10	5	125.0	24.0	2
SMDJ70A	PGP	DGP	70.0	77.80	86.00	5	113.0	26.6	2
SMDJ75	PGQ	DGQ	75.0	83.30	102.00	5	134.0	22.4	2
SMDJ75A	PGR	DGR	75.0	83.30	92.10	5	121.0	24.8	2
SMDJ78	PGS	DGS	78.0	86.70	106.00	5	139.0	21.6	2
SMDJ78A	PGT	DGT	78.0	86.70	95.80	5	126.0	23.8	2
SMDJ80	PGA	DGA	80.0	88.96	108.80	5	143.2	21.0	2
SMDJ80A	PGB	DGB	80.0	88.80	97.60	5	129.6	23.2	2
SMDJ85	PGU	DGU	85.0	94.40	115.00	5	151.0	19.9	2
SMDJ85A	PGV	DGV	85.0	94.40	104.00	5	137.0	21.9	2
SMDJ90	PGW	DGW	90.0	100.00	122.00	5	160.0	18.8	2
SMDJ90A	PGX	DGX	90.0	100.00	111.00	5	146.0	20.6	2
SMDJ100	PGY	DGY	100.0	111.00	136.00	5	179.0	16.8	2
SMDJ100A	PGZ	DGZ	100.0	111.00	123.00	5	162.0	18.5	2
SMDJ110	PHD	DHD	110.0	122.00	149.00	5	196.0	15.3	2
SMDJ110A	PHE	DHE	110.0	122.00	135.00	5	177.0	17.0	2
SMDJ120	PHF	DHF	120.0	133.00	163.00	5	214.0	14.0	2
SMDJ120A	PHG	DHG	120.0	133.00	147.00	5	193.0	15.5	2
SMDJ130	PHH	DHH	130.0	144.00	176.00	5	231.0	13.0	2
SMDJ130A	PHK	DHK	130.0	144.00	159.00	5	209.0	14.4	2

TYPICAL DEVICE CHARACTERISTICS

ELECTRICAL CHARACTERISTICS PER LINE @ 25°C Unless Otherwise Specified

PART NUMBER (Notes 1-3)	DEVICE MARKING		REVERSE STAND-OFF VOLTAGE V_{RWM} VOLTS	BREAKDOWN VOLTAGE $V_{(BR)} @ I_T$ VOLTS		TEST CURRENT @ I_T mA	MAXIMUM CLAMPING VOLTAGE (Fig. 2) @ I_P V_C VOLTS	MAXIMUM REVERSE SURGE CURRENT @ I_{PP} AMPS	MAXIMUM REVERSE LEAKAGE CURRENT @ V_{RWM} I_R μA
	UNI	BI		MIN	MAX				
	SMDJ140	PHA	DHA	140.0	155.68	190.40	5	250.6	12.0
SMDJ140A	PHB	DHB	140.0	155.00	171.00	5	226.8	13.2	2
SMDJ150	PHL	DHL	150.0	167.00	204.00	5	268.0	11.2	2
SMDJ150A	PHM	DHM	150.0	167.00	185.00	5	243.0	12.4	2
SMDJ160	PHN	DHN	160.0	178.00	218.00	5	287.0	10.5	2
SMDJ160A	PHP	DHP	160.0	178.00	197.00	5	259.0	11.6	2
SMDJ170	PHQ	DHQ	170.0	189.00	231.00	5	304.0	9.9	2
SMDJ170A	PHR	DHR	170.0	189.00	209.00	5	275.0	10.9	2
SMDJ180	PHS	DHS	180.0	200.16	244.80	5	322.2	9.3	2
SMDJ180A	PHT	DHT	180.0	200.00	220.00	5	291.6	10.3	2
SMDJ190	PHU	DHU	190.0	211.28	258.40	5	340.1	8.8	2
SMDJ190A	PHV	DHV	190.0	211.00	232.00	5	307.8	9.8	2
SMDJ200A	PHW	DHW	200.0	224.00	247.00	5	324.0	9.3	2
SMDJ220A	PHX	DHX	220.0	246.00	272.00	5	356.0	8.4	2
SMDJ250A	PHZ	DHZ	250.0	279.00	309.00	5	405.0	7.4	2
SMDJ300A	PJE	DJE	300.0	335.00	371.00	5	486.0	6.2	2
SMDJ350A	PJG	DJG	350.0	391.00	432.00	5	567.0	5.3	2
SMDJ400A	PJK	DJK	400.0	447.00	494.00	5	648.0	4.6	2
SMDJ440A	PJM	DJM	440.0	492.00	543.00	5	713.0	4.2	2

NOTE

1. Suffix 'A' denotes 5% tolerance, without 'A' denotes 10% tolerance.
2. Add suffix 'C' or 'CA' after part number to specify a bidirectional device.
3. For bidirectional devices having a V_{RWM} of 10 Volts and under, the I_R limit is double.

TYPICAL DEVICE CHARACTERISTICS

FIGURE 1
PEAK PULSE POWER VS PULSE TIME

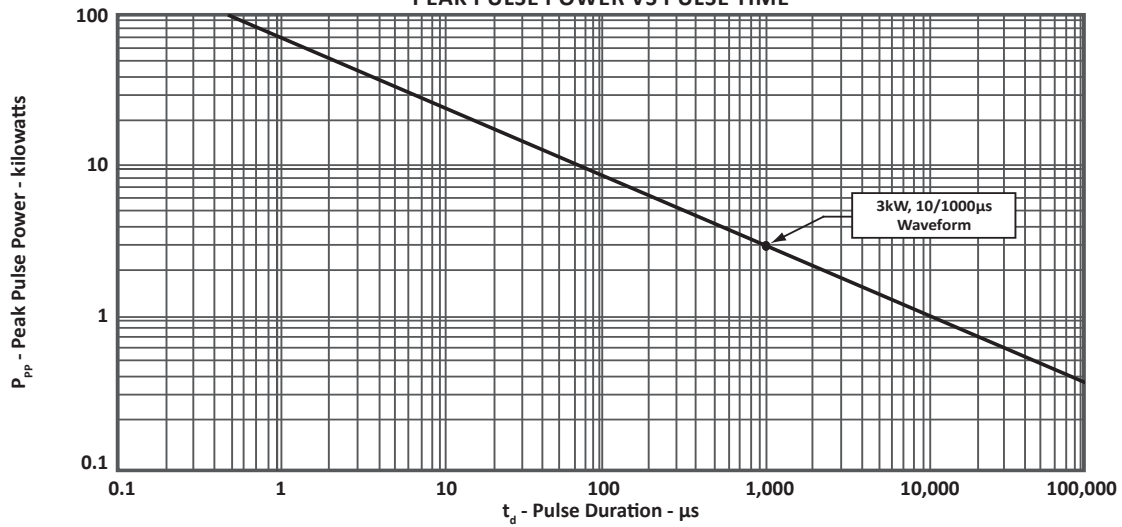

FIGURE 2
PULSE WAVEFORM

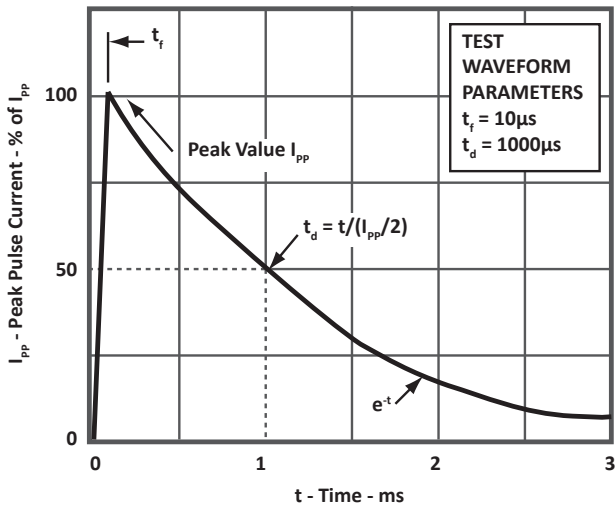
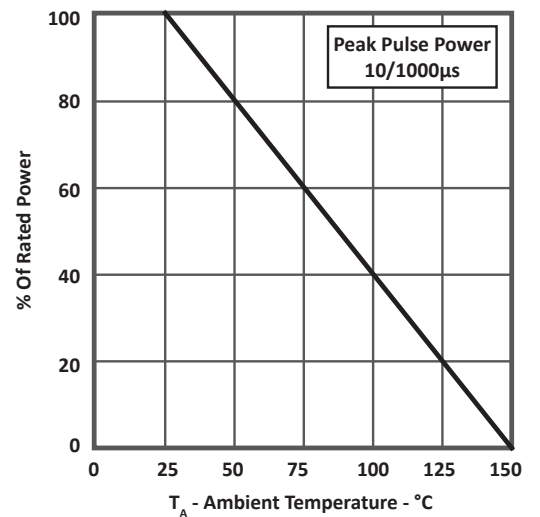
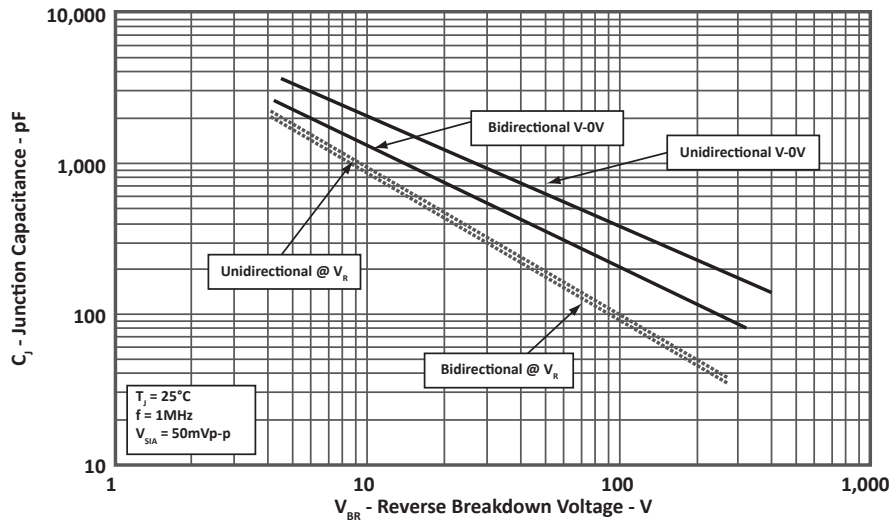

FIGURE 3
POWER DERATING CURVE



TYPICAL DEVICE CHARACTERISTICS

**FIGURE 4
TYPICAL JUNCTION CAPACITANCE**



**FIGURE 5
MAXIMUM NON-REPETITIVE FORWARD SURGE CURRENT**

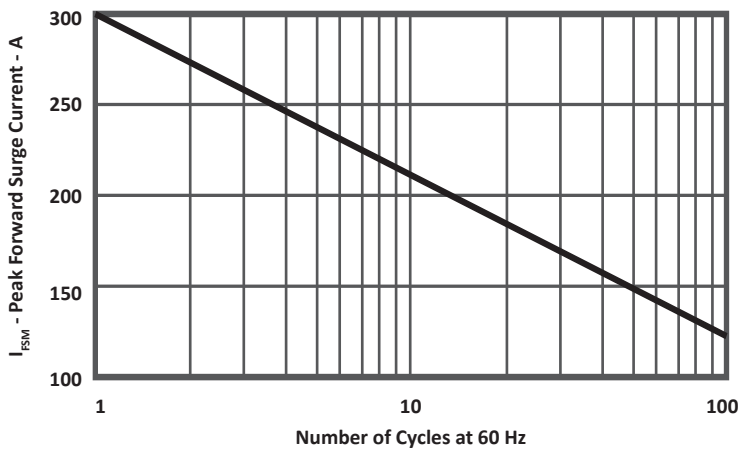

**FIGURE 6
STEADY STATE POWER DERATING CURVE**

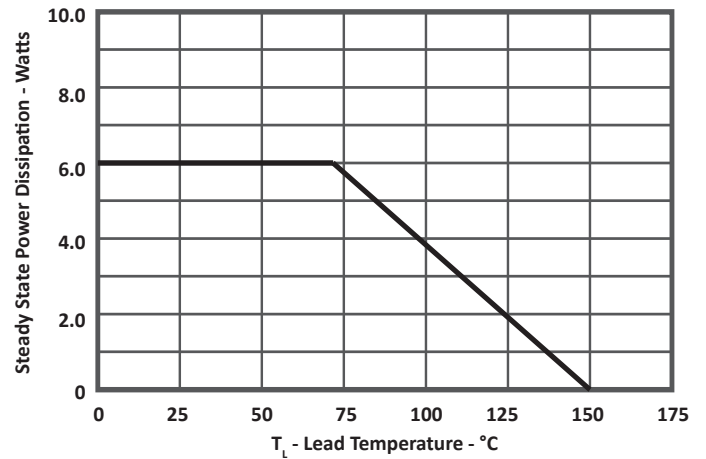

DO-214AB PACKAGE INFORMATION

OUTLINE DIMENSIONS

DIM	MILLIMETERS		INCHES	
	MIN	MAX	MIN	MAX
A	2.86	3.16	0.114	0.126
B	6.52	7.02	0.260	0.280
C	5.52	6.15	0.220	0.245
D	1.98	2.59	0.079	0.103
E	0.75	1.51	0.030	0.060
F	0.00	0.20	0.000	0.008
G	7.64	8.02	0.305	0.320
H	0.15	0.30	0.006	0.012

NOTES

1. Dimensions are exclusive of mold flash and metal burrs.

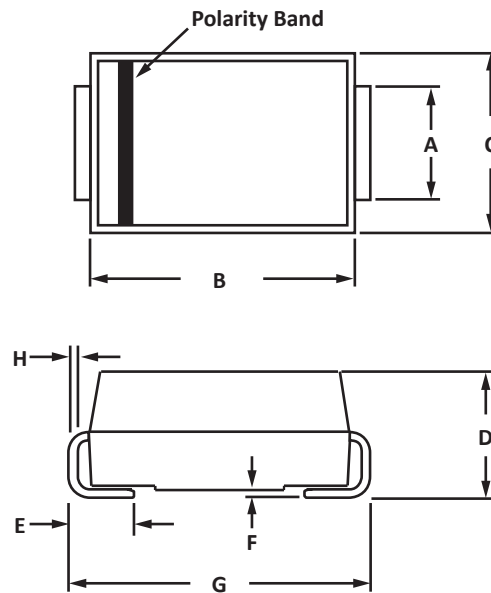

PAD LAYOUT DIMENSIONS

DIM	MILLIMETERS		INCHES	
	MIN	MAX	MIN	MAX
A	3.43	-	0.135	-
B	2.03	-	0.080	-
C	-	4.32	-	0.170
D	2.03	-	0.080	-

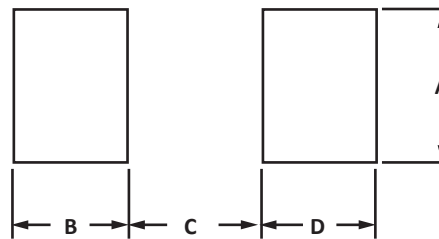

TAPE AND REEL

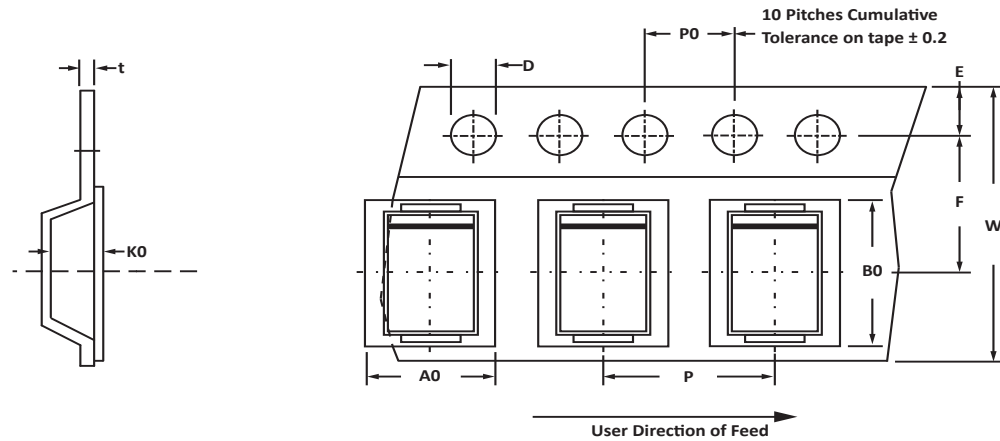

SPECIFICATIONS

REEL DIA.	TAPE WIDTH	A0	B0	K0	D	E	F	W	P0	P	tmax
330mm (13")	16mm	6.05 ± 0.10	8.31 ± 0.10	2.54 ± 0.10	1.55 ± 0.05	1.75 ± 0.10	7.5 ± 0.10	16.00 ± 0.30	4.00 ± 0.10	8.00 ± 0.10	0.4

NOTES

- Dimensions are in millimeters.
- Surface mount product is taped and reeled in accordance with EIA-481.
- Suffix - T13 = 13" Reel - 3,000 pieces and T500 = 7" Reel - 500 pieces per 16mm tape.
- Marking on Part - marking code (see page 2), date code, logo and cathode defined by polarity band.

ORDERING INFORMATION

BASE PART NUMBER (Voltage = xx)	LEADFREE SUFFIX	TAPE SUFFIX	QTY/REEL	REEL SIZE	TUBE QTY
SMDJxx	N/A	-T13	3,000	13"	N/A
SMDJxxA	N/A	-T13	3,000	13"	N/A
SMDJxxC	N/A	-T13	3,000	13"	N/A
SMDJxxCA	N/A	-T13	3,000	13"	N/A
SMDJxx	N/A	-T500	500	7"	N/A
SMDJxxA	N/A	-T500	500	7"	N/A
SMDJxxC	N/A	-T500	500	7"	N/A
SMDJxxCA	N/A	-T500	500	7"	N/A

This device is only available in a Lead-Free configuration.

COMPANY INFORMATION

COMPANY PROFILE

In business more than 25 years, ProTek Devices™ is a privately held semiconductor company. The company offers a product line of overvoltage protection and overcurrent protection components. These include transient voltage suppressor array (TVS arrays) avalanche breakdown diode, steering diode TVS array and electronics SMD chip fuses. These components deliver circuit protection in electronic systems from numerous overvoltage and overcurrent events. They include lightning; electrostatic discharge (ESD); nuclear electromagnetic pulses (NEMP); inductive switching; and electromagnetic interference (EMI) / radio frequency interference (RFI). ProTek Devices also offers LED wafer die for ESD protection and related high frequency products. ProTek Devices is ISO 9001:2015 certified.

CONTACT US

Corporate Headquarters

2929 South Fair Lane
Tempe, Arizona 85282
USA

By Telephone

General: 602-431-8101
Sales: & Marketing: 602-414-5109
Customer Service: 602-414-5114
Product Technical Support: 602-414-5107

By Fax

General: 602-431-2288

By E-mail:

Asia Sales: asiasales@protekdevices.com
Europe Sales: europesales@protekdevices.com
U.S. Sales: ussales@protekdevices.com
Distributor Sales: distysales@protekdevices.com
Customer Service: service@protekdevices.com
Technical Support: support@protekdevices.com

ProTek Devices (Asia Pacific) Pte. Ltd.

8 Ubi Road 2, #06-19
Zervex
Singapore - 408538
Tel: +65-67488312
Fax: +65-67488313

Web

www.protekdevices.com

COPYRIGHT © ProTek Devices 2013 - This literature is subject to all applicable copyright laws and is not for resale in any manner.

SPECIFICATIONS: ProTek reserves the right to change the electrical and or mechanical characteristics described herein without notice.

DESIGN CHANGES: ProTek reserves the right to discontinue product lines without notice and that the final judgement concerning selection and specifications is the buyer's and that in furnishing engineering and technical assistance. ProTek assumes no responsibility with respect to the selection or specifications of such products. ProTek makes no warranty, representation or guarantee regarding the suitability of its products for any particular purpose, nor does ProTek assume any liability arising out of the application or use of any product or circuit and specifically disclaims any and all liability without limitation special, consequential or incidental damages.

LIFE SUPPORT POLICY: ProTek Devices products are not authorized for use in life support systems without written consent from the factory.