



INSTALLATION MANUAL

RedBaron XP Galactica

Anti-collision LED Light

AVE-RBXP-001-IM

Table of Contents

PART 0	DOCUMENT ADMINISTRATION	3
0.1	DOCUMENT APPROVAL	3
0.2	AMENDMENT RECORD PROCEDURE	3
0.3	EFFECTED PAGES PROCEDURE	4
PART 1	INSTALLATION DATA	5
1.1	REDBARON XP GALACTICA™	5
1.2	OPERATING INSTRUCTIONS	5
1.3	INSTALLATION SCHEMATIC / WIRING DIAGRAM	6
1.4	CONTROL & POWER INPUTS	7
1.5	TECHNICAL SPECIFICATION	7
1.6	TECHNICAL DRAWING	9
1.7	WIRING CHART	10
1.8	OPTIC SIMULATION	11
1.9	EQUIPMENT LIMITATION	12
1.10	CARE AND CLEANING OF LIGHTS	12
1.11	TESTING OF THE LIGHT BEFORE INSTALLATION	12
1.12	NOTES ON INSTALLATION	13
1.13	ETSO REQUIREMENT DEVIATION	13
1.14	CONTINUED AIRWORTHINESS INFORMATION	13
1.15	ROHS COMPLIANCE STATEMENT	16
1.16	EU REACH REGULATION (EC) No. 1907/2006	16

Part 0 Document Administration

0.1 Document approval

This document has been established in accordance with an alternative procedure to DOA approved under EASA AP429.

This installation manual is applicable for following part numbers:

- **RedBaron XP Galactica – Red** AVE-RBXPR-001 Mod(1)
- **RedBaron XP Galactica – White** AVE-RBXPW-001 Mod(1)

Compiled by: _____ 06 August 2021
Petr Jaroš
Engineer, Aveo Engineering Group, s.r.o.

Approved by: _____ 06 August 2021
Georg Hartl
Head of DO, Aveo Engineering Group, s.r.o.

0.2 Amendment Record procedure

The master copy of this document shall be kept electronically as a read only document under the control of Aveo Engineering Group, s.r.o. as Master Copy.

ALL amendments to this manual will initiate a raise of Issue

ALL raises of issue will be given a sequential Alphabetic Issue Ident sequentially from 01 to 99 in Table 01 - **Issue No:** Column– Initial Issue of Document will be "01"

ALL Issues of this document will be approved by Head of DO

Issue No.	Details	Date	Effected Pages
01	Initial Issue	18.Dec.2014	ALL
02	Addition of Statement p.3 and Occurrence Reporting p. 11, remove failing LED	14.Jun.2015	3, 11, 12
03	Addition of FAA required statements	10.Nov.2015	7, 9
04	Add description and P/N of RB Mini Add wiring diagram Add dimensions and specifications Update geometry Add geometry	19.Jan. 2017	5 7 8 10 11

	Add RB Mini to limitations Add RB Mini to ETSO Requirement Deviation Update warranty Amend figure legend figure 2		12 14 15 16
05	Change of structure of document Removal of RedBaron Mini Galactica Addition of optic simulation diagrams Update of Care and Cleaning section	06.Aug.2021	ALL
Table 01: Document Amendment Record Table			

0.3 *Effected Pages Procedure*

ALL pages affected by **ANY** raise of issue of this manual will be listed in Table 01 - **Effected Pages** Column.

The reason(s) for **ALL** raise of issue and description of change due to raise of issue will be provided for **ALL** raises of issue in Table 01 - **Details** Column.

Changes from the previous issue are highlighted by **YELLOW HIGHLIGHTING** over new content. AND **YELLOW HIGHLIGHTING** AND **CROSSING OUT** of deleted content.

Example (~~CROSSING OUT~~)

Part 1 Installation data

1.1 RedBaron XP Galactica™

The **RedBaron XP Galactica** anti-collision lights were designed for certified aircraft requirements. They represent the cutting edge in optics design and the use of LED arrays that have been optimized for coverage patterns. The exclusive Aveo Rocky Reflectors™ are what separates these lights from any in the industry, and they have been moulded after exhaustive modelling and testing in our parent company's world class LED-array measurement lab.

The RedBaron XP Galactica™ version incorporates 40 of the brightest LEDs available in the world today, with chromaticity and intensity compliant to all international aviation and safety standards. The optical performance is incredible, and these are the ideal replacement unit for any anti-collision light system in existence.

The RedBaron XP Galactica™ light feature an exclusive Aveo internal reflection system to achieve the appropriate arcs of intensities, and these lights exceed the requirements by a wide margin. Be Seen, Not Sorry is our mantra, and with the RedBaron XP Galactica™ light your aircraft will be seen farther away than any other lighting system on the market, and all with the exclusive Aveo patented electronic circuitry.

RedBaron XP Galactica – Red	PN: AVE-RBXPR-001 Mod(1)
RedBaron XP Galactica – White	PN: AVE-RBXPW-001 Mod(1)
CAP	PN: 0100012
BASE	PN: 0100011
O-RING	PN: ISO 3601

1.2 Operating Instructions

When installed on the aircraft, using the aircraft's power (14 or 28 volts), the light will be at its maximum intensity.

Operating Voltage range is +9...+36VDC.

1.3 Installation Schematic / Wiring Diagram



Notes: - Synchronization mutually interconnect with other Aveo lights for full featured strobe synchro
 - For installation at non metal surfaces connect earth pigtail to the airframe

1.4 Control & Power Inputs

YELLOW:	+UCC - positive strobe power supply line
BLACK:	GND - negative common power supply line (ground)
BLUE:	SYNC - strobe synchronization line (Mutually interconnect on all installed AveoFlash lights)
BARE:	Aircraft airframe connection

1.5 Technical Specification

Dimensions:	64 mm x 64 mm x 39.8 mm 2.52" x 2.52" x 1.565"
Weight:	0.145 kg / 0.32 lb
Operating Voltage Range:	9 – 36 VDC
Input Power – Red Strobe:	57.96W @14V, 64.68W @28V
Input Power – White Strobe:	59.10W @14V, 78.53W @28V
Input Current – Red Strobe:	4.14A @14V, 2.31A @28V
Input Current – White Strobe:	4.22A @14V, 2.8A @28V
Voltage protection:	a. Transient voltage: +60VDC b. Under-voltage lockout: +9VDC, not more c. Over-voltage lockout: +36VDC, not less
Repetition Flash Rate of Strobe:	50 cycles per minute
Ambient temperature:	-55°C...+85°C / -67°F...+185°F
Overheat protection:	Yes
Exceed requirements of:	- ETSO C96a - SAE AS8017a - DO-160F
Recommended size of mounting screw:	M5x50mm (AVS-P000102111-A3A) or equivalent

Device RTCA/DO160 qualified:

Test title	Section	Category
Temperature / Altitude	4	F2
Temperture variation	5	A
Humidity	6	C
Operational Shock	7	A
Vibration	8	S & R
Explosive Atmosphere	9	H
Waterproofness	10	S
Fluid Susceptibility	11	F
Sand and dust	12	S
Fungus	13	F
Salt Spray	14	T
Magnetic Effects	15	Z
Power Input	16	B
Voltage Spike	17	B
Audio Freq. Conducted Susceptibility	18	B
Induced Signal Susceptibility	19	AC
Radiated and conducted Susceptibility	20	T
Radiated and conducted Emissions	21	H
Lightening Induced Transient Susceptibility	22	A2E2X
Lightening direct effects	23	2A2A
Icing	24	A
Electrostatic Discharge	25	A

1.6 Technical Drawing

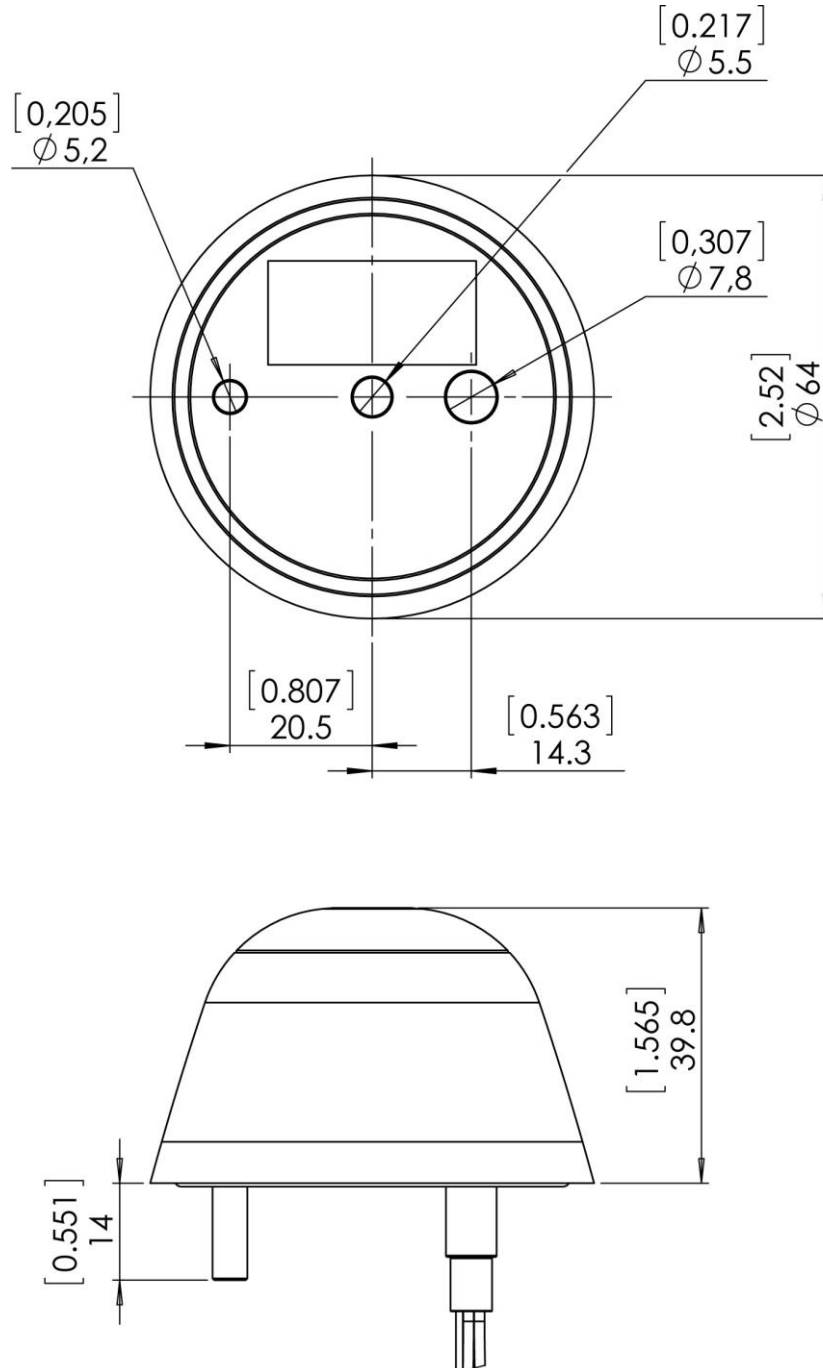

Dimensions in [inches] mm

1.7 Wiring Chart

Use diagram below defining the wiring size depending on the current and the wire length. Make sure you add up the current for all connected lights. If current is not given, then divide the power by the voltage.

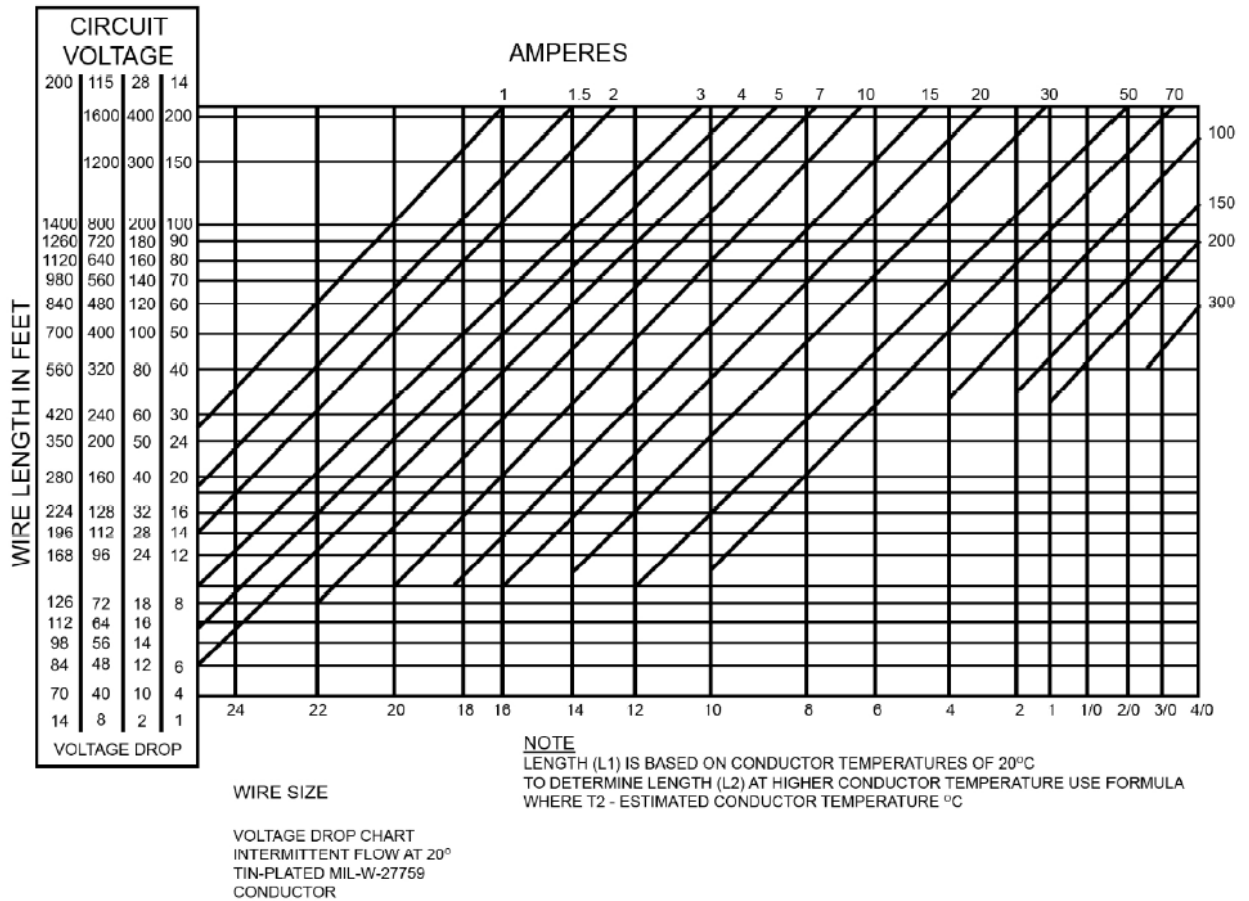

1.8 Optic Simulation

RedBaron XP Galactica – Red AVE-RBXPR-001 Mod(1)

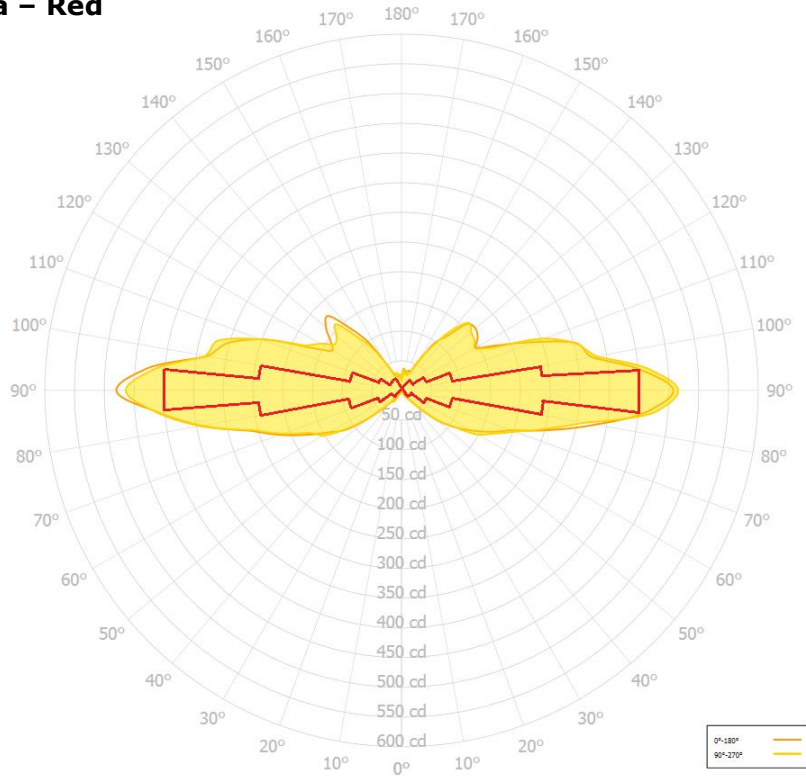

RedBaron XP Galactica – White AVE-RBXPW-001 Mod(1)

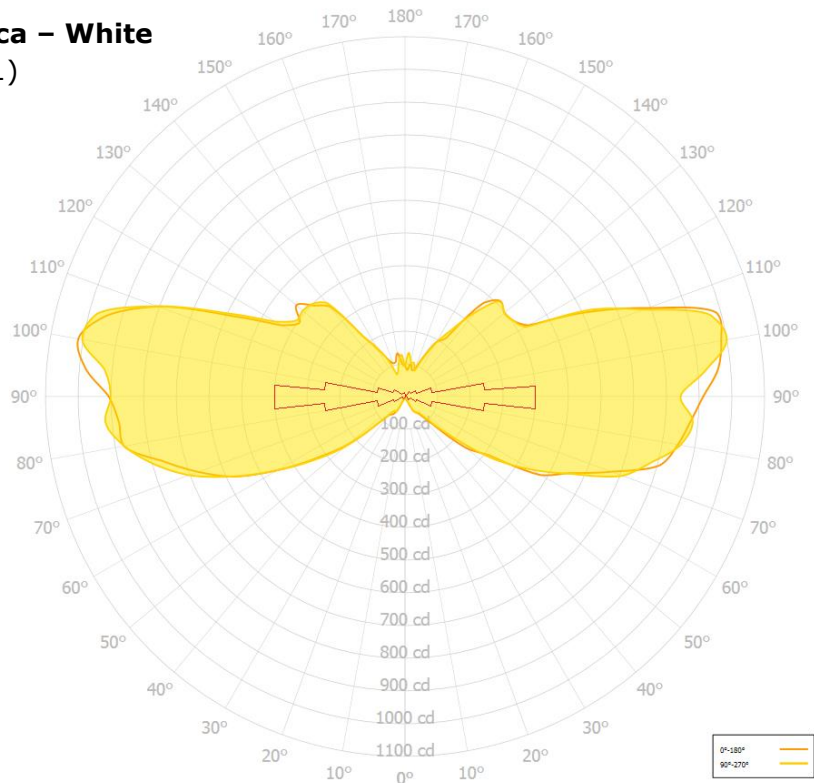

1.9 Equipment Limitation

RedBaron XP Galactica™ should only be powered by 9-36 VDC, typically a 14 or 28 volt aircraft battery.

This article meets the minimum performance and quality control standards required by the technical standard order ETSO C96a. Installation of this article requires separate approval.

Deviations

This article deviates from the ETSO C96a by the usage of newer revisions of the following standards:

SAE AS 8017 rev. B used instead SAE AS 8017 rev. A

1.10 Care and Cleaning of Lights

Aveo Engineering Aviation Lights are factory polished and delivered as ready to install on the aircraft.

If the lights need a deeper cleaning, they should be polished with a quality lamb's wool sheet that is suitable also for deeper polishing. Under no circumstances should any petroleum based product be used to clean the lights.

1.11 Testing of the Light Before Installation

All Aveo Aviation lights undergo rigorous testing prior to being released from our engineering manufacturing department. This testing involves a burn-in time as well as other function testing. No light is released for sale without undergoing this extensive operational testing.

When you receive the Aveo Galactica RedBaron light, and wish to test the function of the light prior to installation on your aircraft, please note the following:

1. Please review the written information that is enclosed in the packaging. Warranty information as well as a cautionary note about power supply removal is enclosed with each package.
2. Remove the light from the package. Note that there are **four (4)** wires coming from each light. These wires are:
 - a. Black wire – Ground wire (negative lead)
 - b. Yellow wire – Anti-collision light function wire (positive lead)
 - c. Blue wire – used if the synchronization of the Aveo lights is selected
 - d. **Bare wire – Airplane airframe connection**
3. Testing of the function of the light can be done with a regular 12V/5A dc power supply (not a battery charger).

Connect the black wire to the ground (negative) leads of a power supply, then connect the yellow wire to the positive (+) leads on the power supply. The anti-collision light should start flashing. Connecting the blue wires from each AveoFlash light together (and not to the ground or positive terminals on the battery) should show that the lights are flashing together and indicates the synchronization feature is working properly. When installed on the aircraft, using the aircraft's power (14 or 28 volts), the light will be at its maximum intensity.

After testing, the light can be installed on the aircraft.

IMPORTANT NOTES:

1. Under no circumstances should any power supply other than a 9-36 VDC, or a 14/28 volt battery be used to test the light. Do not use: Battery chargers, battery back-up power devices, or other bench avionics testing methods to test the aviation light. The light is functional between 9 and 36 volts. Use of a battery charger or other power unit to test the light will void the warranty and may damage the light.
2. All power supplies for existing strobe lights, flasher beacons, etc. are required to be removed from the aircraft prior to the installation of the Aveo light.

If you have any questions about the installation of the lights, please refer to our web site: <http://www.aveoengineering.com>, and check FAQ and other links on our aviation lights web page.

1.12 Notes on Installation

Please use M5x45mm (DIN912) or equivalent mounting screw for the installation. Spread the tightening forces evenly around the mounting hole. Stainless steel screw is recommended. Length depends upon placement location on aircraft. **For installation at non metal surfaces connect earth pigtail to the airframe**

1.13 ETSO Requirement Deviation

Paragraph a. (1) through a. (3) of **ETSO-C96a** requires the minimum performance standards (MPS) listed in SAE8017A and RTCA DO-160. AVEO aviation light Part Number **AVE-RBXPW-001/AVE-RBXPR-001** meets the Minimum Performance Standard (MPS) listed in SAE AS8017B and RTCA DO-160E/F and was authorized with deviation by EASA. Detailed information relating to this approved deviation can be found at <http://www.aveoengineering.com>.

1.14 Continued Airworthiness Information

This product is delivered with form F-AVE-001A which is for the operator to report any occurrences to Aveo Engineering as the ETSO holder. The form contains the Aveo Engineering telephone number and the occurrence e-mail address (occurrence@aveoengineering.com). **The operator must report immediately** as the ETSO holder must report occurrences having a potential for an unsafe condition within 72 hours.

a. Circuit/Wiring Protection

Each RedBaron XP Galactica series light features a **Negative Temperature Coefficient** (NTC) circuit that limits internal temperatures by attenuating operating current (with a corresponding reduction of brightness) when internal temperatures reach a certain threshold. This proprietary circuitry serves to protect the light itself, and associated aircraft wiring, against a thermal runaway condition. It's recommended that the operation of strobes without airflow be limited to avoid heat build up and this NTC circuitry feature is designed to more than triple the life of the LEDs and electronic components thereby providing an even great margin of safety for continued airworthiness due to the dramatic enhancement of electronics reliability.

b. Periodic Inspection Procedure for Galactica Series

The Aveo RedBaron Galactica lights should always be checked for proper operation during pre-flight. This procedural information is already provided in all general aviation aircraft flight manuals.

The lights should be visually inspected for general condition, proper operation, and correct installation at each annual and/or 100 hours inspection. In addition refer to section 1.10 of installation manual for detailed cleaning instructions.

Turn the lights on and do the following:

1. Put on polarized sunglasses or welder goggles to prevent eye damage when looking into the lights.
2. Examine the individual LEDs as per the diagram below. If any of the conditions as indicated on the diagram are exceeded, the light shall be removed and sent to Aveo Engineering for replacement under the Aveo Warranty Program.

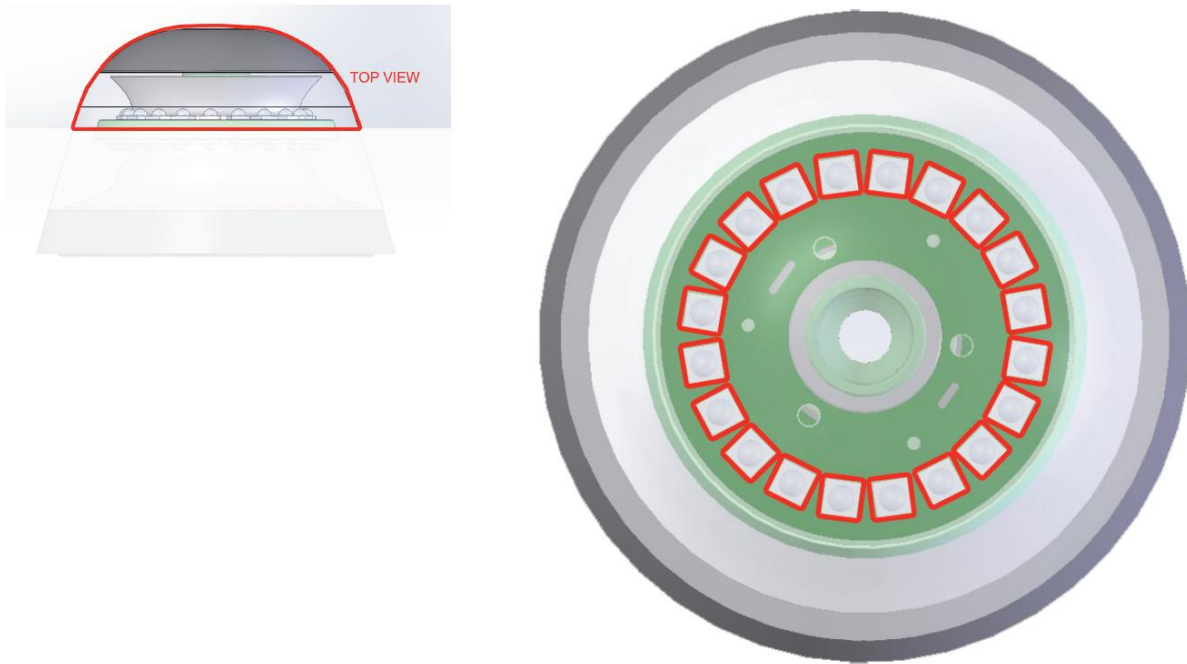

Figure 1: Top LEDs

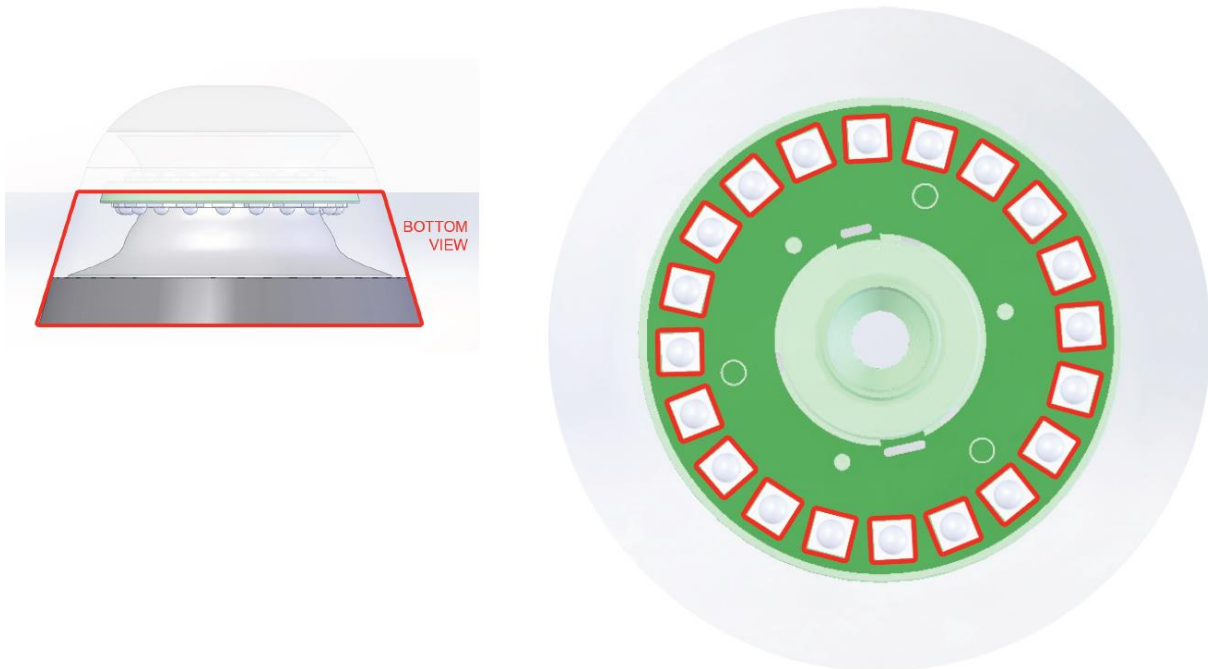

Figure 2: Bottom LEDs

1.15 RoHS Compliance Statement

Scope

This statement clarifies Aveo Engineering's compliance with European Union Directive 2015/863/EU on the restriction of the use of certain hazardous substances in electrical and electronic equipment ("RoHS") that took effect on June 4, 2015. The RoHS Directive restricts the sale of electronic equipment containing certain hazardous substances in the European Union including:

Cadmium(Cd): 0.01%

Mercury: 0.1%

Lead(Pb) : 0.1%

Hexavalent chromium (Cr6+) : 0.1%

Polybrominated biphenyls (PBB): 0.1 %;

Polybrominated diphenyl ethers (PBDE): 0.1 %

Bis(2-Ethylhexyl) phthalate (DEHP): 0.1% (added in 2015);

Benzyl butyl phthalate (BBP): 0.1% (added in 2015);

Dibutyl phthalate (DBP): 0.1% (added in 2015);

Diisobutyl phthalate (DIBP): 0.1% (added in 2015)

Compliance

Aveo Engineering certifies that all products sourced from manufacturing facilities comply with the environmental standards set forth by the Directive 2015/863/EU, recast amendment of RoHS Directive 2011/65/EU Article (4), and do not contain any of the above-mentioned, 10 hazardous substances above the specified limits. All products manufactured by Aveo Engineering are RoHS-compliant. With regards to RoHS-2 CE marking, product packaging is labeled attesting conformity if required.

References

Directive 2015/863/EU of the European Parliament and of the Council on the restriction of the use of certain hazardous substances in electrical and electronic equipment.

1.16 EU REACH Regulation (EC) No. 1907/2006

Aveo Engineering declares that no chemicals are produced and that none of the chemicals used during the production process or needed for the product maintenance or service, is listed on the current European Chemicals Agency's Candidate list of Substances of Very High Concern for Authorization.